

# CONTRACTOR (Z10-L6)

## Classic 6

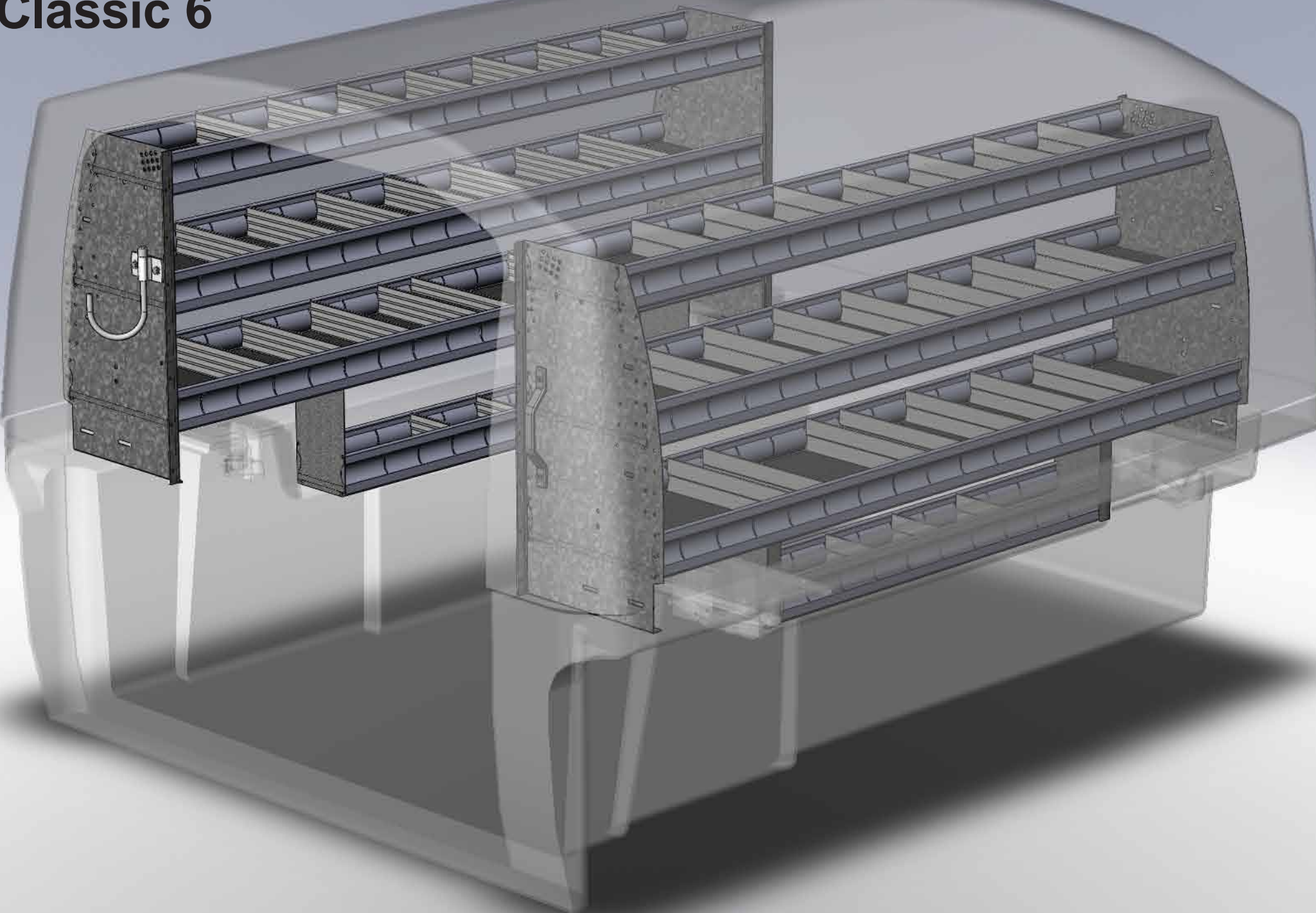
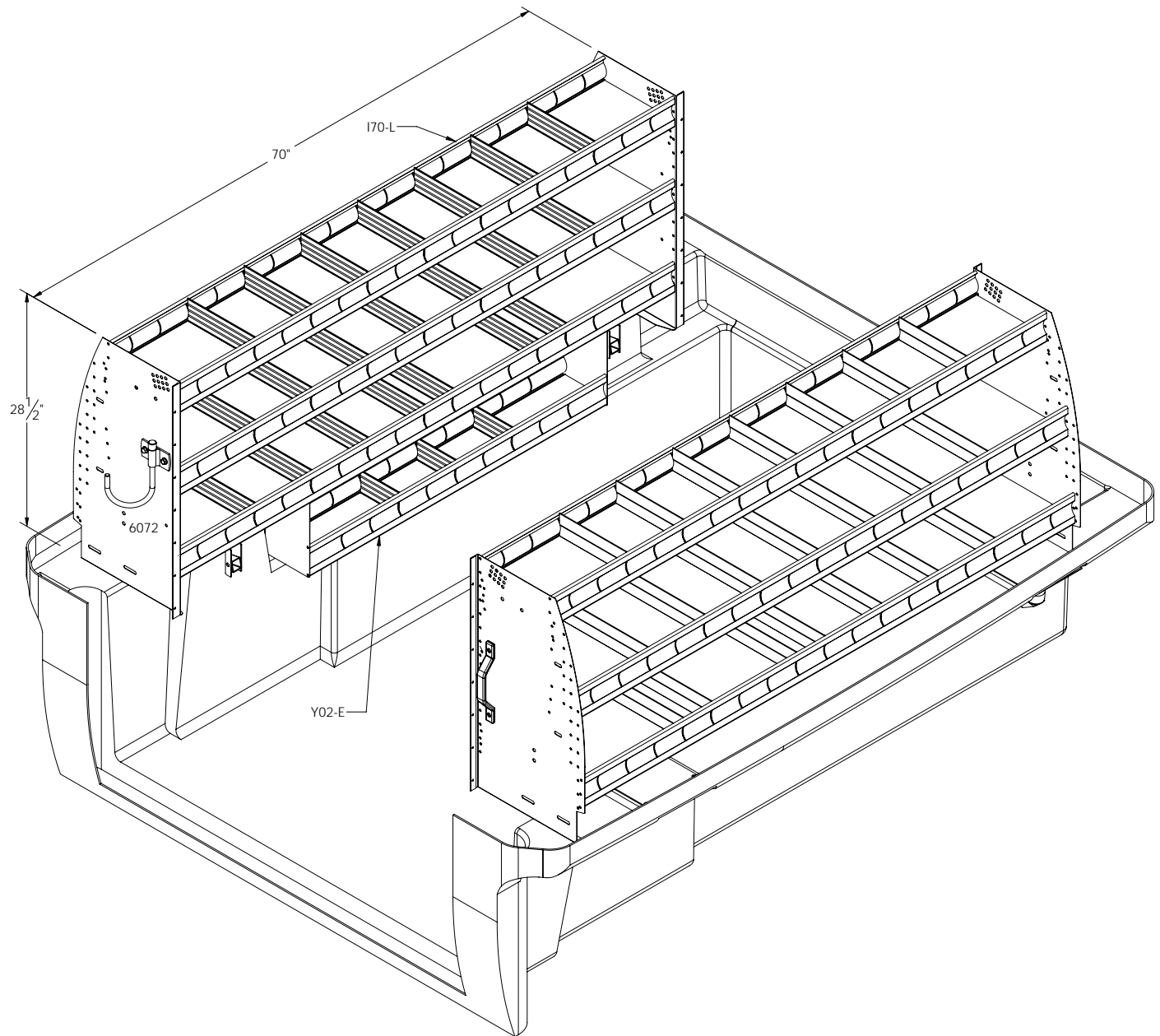

TABLE DE NOMENCLATURE / BOM TABLE		
No	DESCRIPTION	QTE/QTY
170-L	CONTOURED SHELF UNIT, 3 DIVIDED SHELVES - 70"W X 28-1/2"H	2
Y02-E	HALF SHELF - 6"D X 42"W	2
6072	SWIVEL HOOK	1
6093	PLASTIC GRAB HANDLE 9-1/2"	1



SPACEKAP CLASSIC 6'

**RANGER DESIGN**  
**SPACEKAP**

PROPRIETARY AND CONFIDENTIAL  
 THE INFORMATION CONTAINED IN THIS DRAWING IS THE SOLE PROPERTY OF RANGER DESIGN INC. ANY REPRODUCTION IN PART OR AS A WHOLE WITHOUT THE WRITTEN PERMISSION OF RANGER DESIGN INC IS PROHIBITED.

TITLE:  
 ENSEMBLE POUR CONTRACTEURS  
 CONTRACTORS PACKAGE

SIZE <b>C</b>	DWG. NO. Z10-L6	REV 0
2010-04-30	SCALE: 1:8	SHEET 1 OF 2

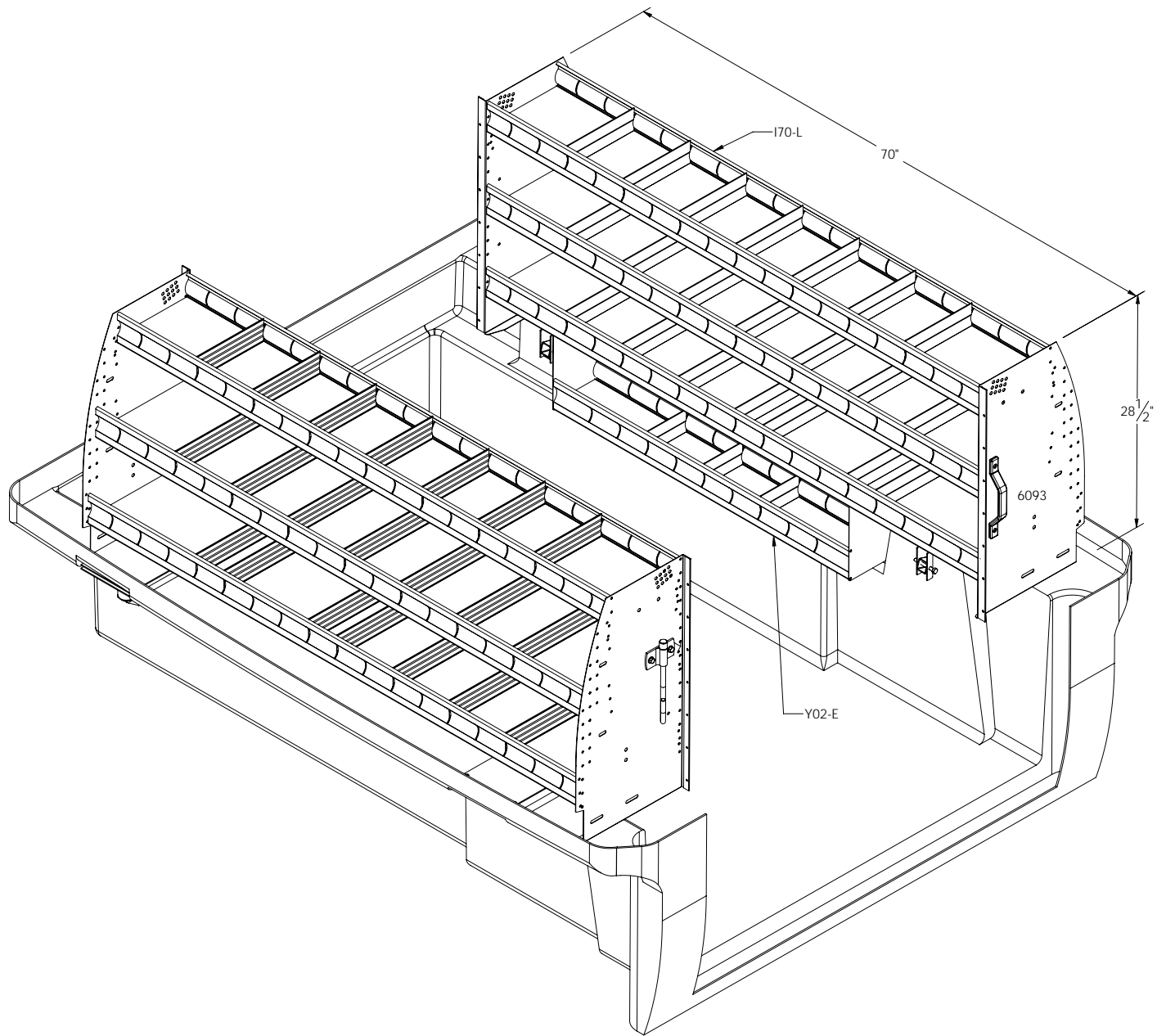

PROPRIETARY AND CONFIDENTIAL  
THE INFORMATION CONTAINED IN THIS DRAWING IS THE SOLE  
PROPERTY OF RANGER DESIGN INC. ANY REPRODUCTION IN PART  
OR AS A WHOLE WITHOUT THE WRITTEN PERMISSION OF  
RANGER DESIGN INC IS PROHIBITED.

TITLE:  
ENSEMBLE POUR CONTRACTEURS  
CONTRACTORS PACKAGE

SIZE <b>C</b>	DWG. NO. Z10-L6	REV 0
2010-04-30	SCALE: 1:8	SHEET 2 OF 2

# PLUMBER / ELECTRICIAN (Z15-L6)

## Classic 6

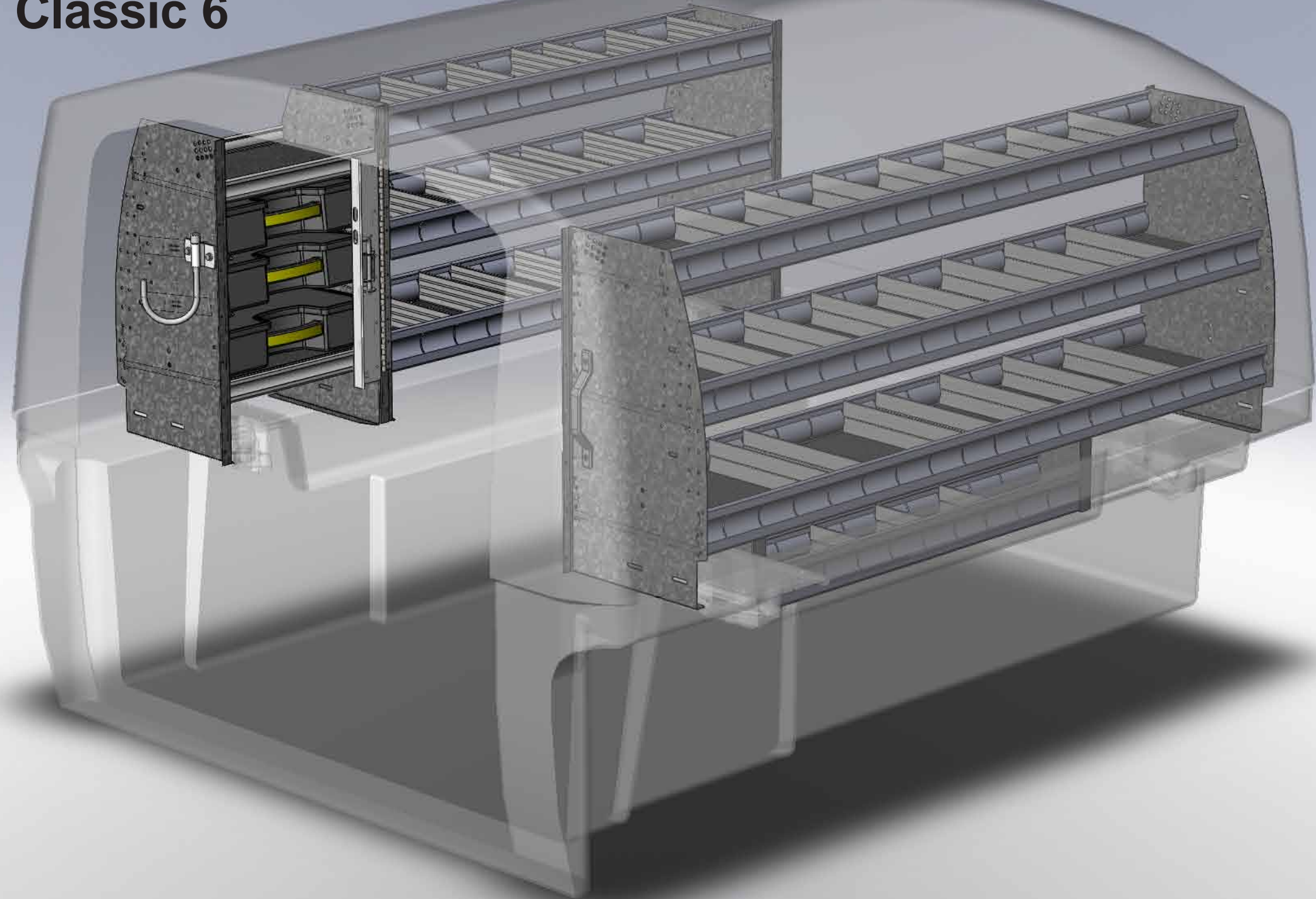
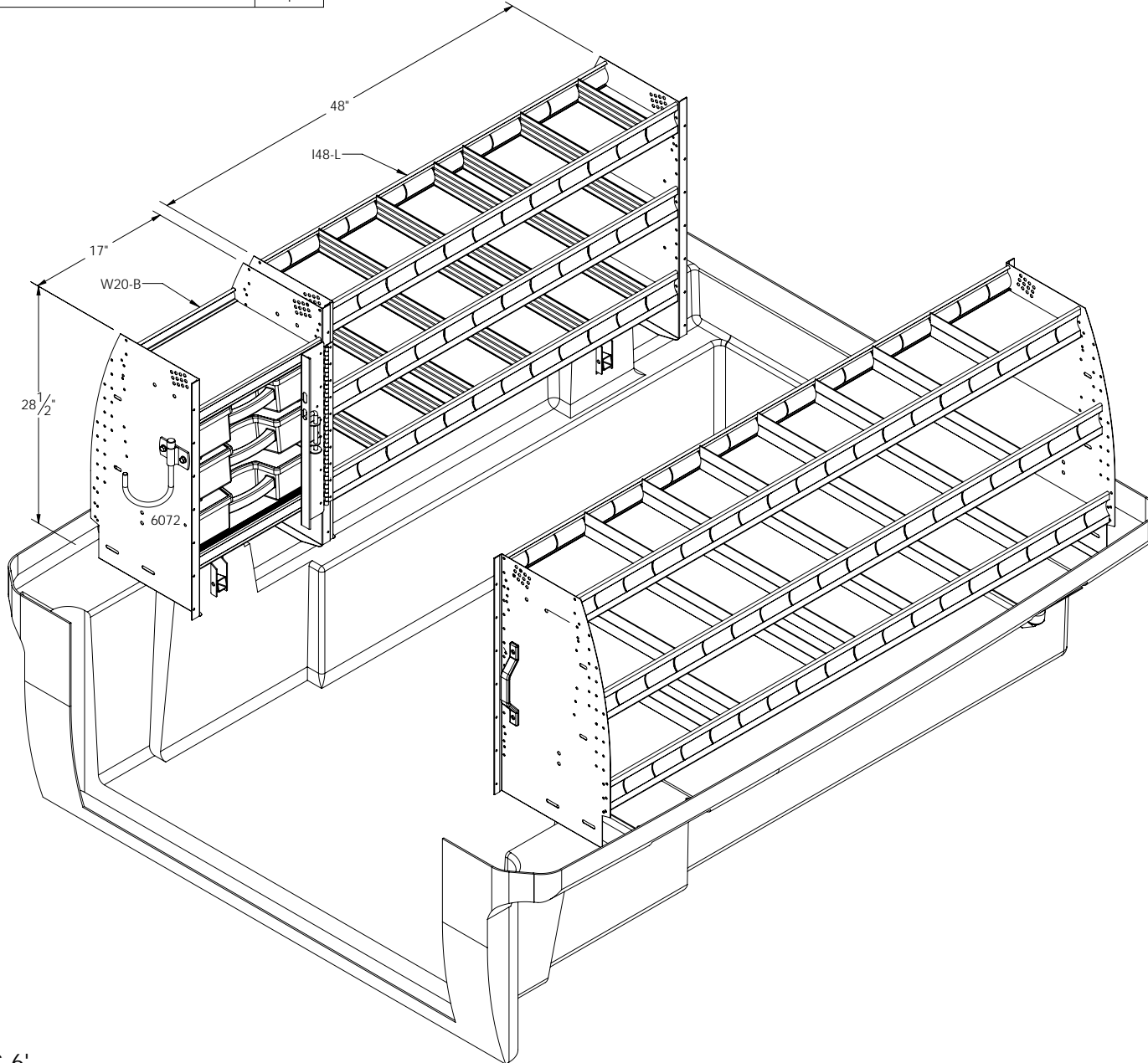

TABLE DE NOMENCLATURE / BOM TABLE		
No	DESCRIPTION	QTE/QTY
I48-L	CONTOURED SHELF UNIT, 3 DIVIDED SHELVES - 48"W X 28-1/2"H	1
W20-B	PARTSKEEPER CABINET W 3 CASES AND 1 SHELF - 17"W X 28-1/2"H	1
6072	SWIVEL HOOK	1
I70-L	CONTOURED SHELF UNIT, 3 DIVIDED SHELVES - 70"W X 28-1/2"H	1
Y02-E	HALF SHELF - 6"D X 42"W	1
6093	PLASTIC GRAB HANDLE 9-1/2"	1



SPACEKAP CLASSIC 6'



PROPRIETARY AND CONFIDENTIAL  
THE INFORMATION CONTAINED IN THIS DRAWING IS THE SOLE  
PROPERTY OF RANGER DESIGN INC. ANY REPRODUCTION IN PART  
OR AS A WHOLE WITHOUT THE WRITTEN PERMISSION OF  
RANGER DESIGN INC IS PROHIBITED.

TITLE:  
ENSEMBLE POUR PLOMBIERS  
PLUMBERS PACKAGE

SIZE <b>C</b>	DWG. NO. Z15-L6	REV 0
2010-04-30	SCALE: 1:8	SHEET 1 OF 2

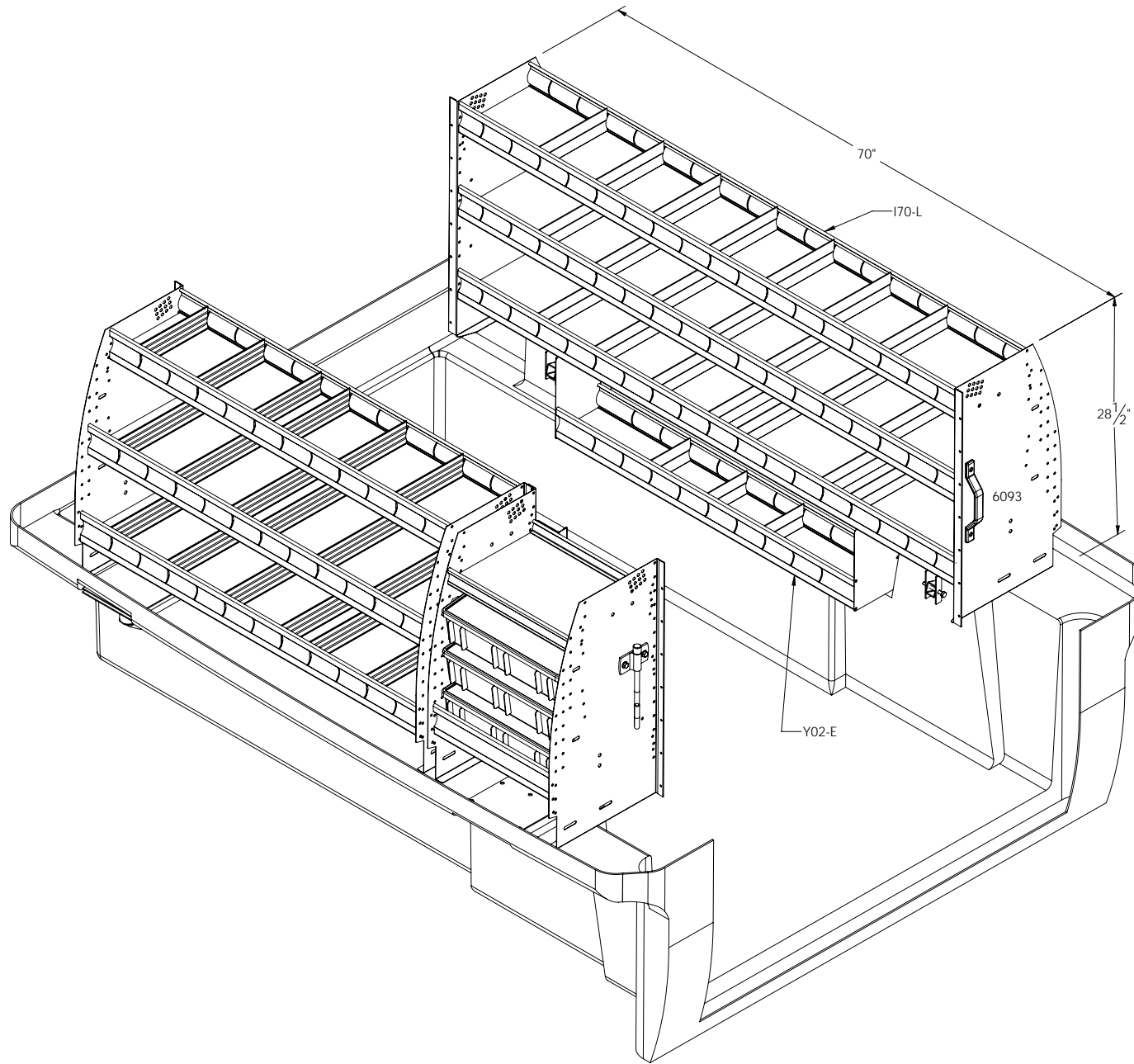

PROPRIETARY AND CONFIDENTIAL  
 THE INFORMATION CONTAINED IN THIS DRAWING IS THE SOLE  
 PROPERTY OF RANGER DESIGN INC. ANY REPRODUCTION IN PART  
 OR AS A WHOLE WITHOUT THE WRITTEN PERMISSION OF  
 RANGER DESIGN INC IS PROHIBITED.

TITLE:  
 ENSEMBLE POUR PLOMBIERS  
 PLUMBERS PACKAGE

SIZE <b>C</b>	DWG. NO. Z15-L6	REV 0
2010-04-30	SCALE: 1:8	SHEET 2 OF 2

# SERVICE (Z16-L6)

## Classic 6

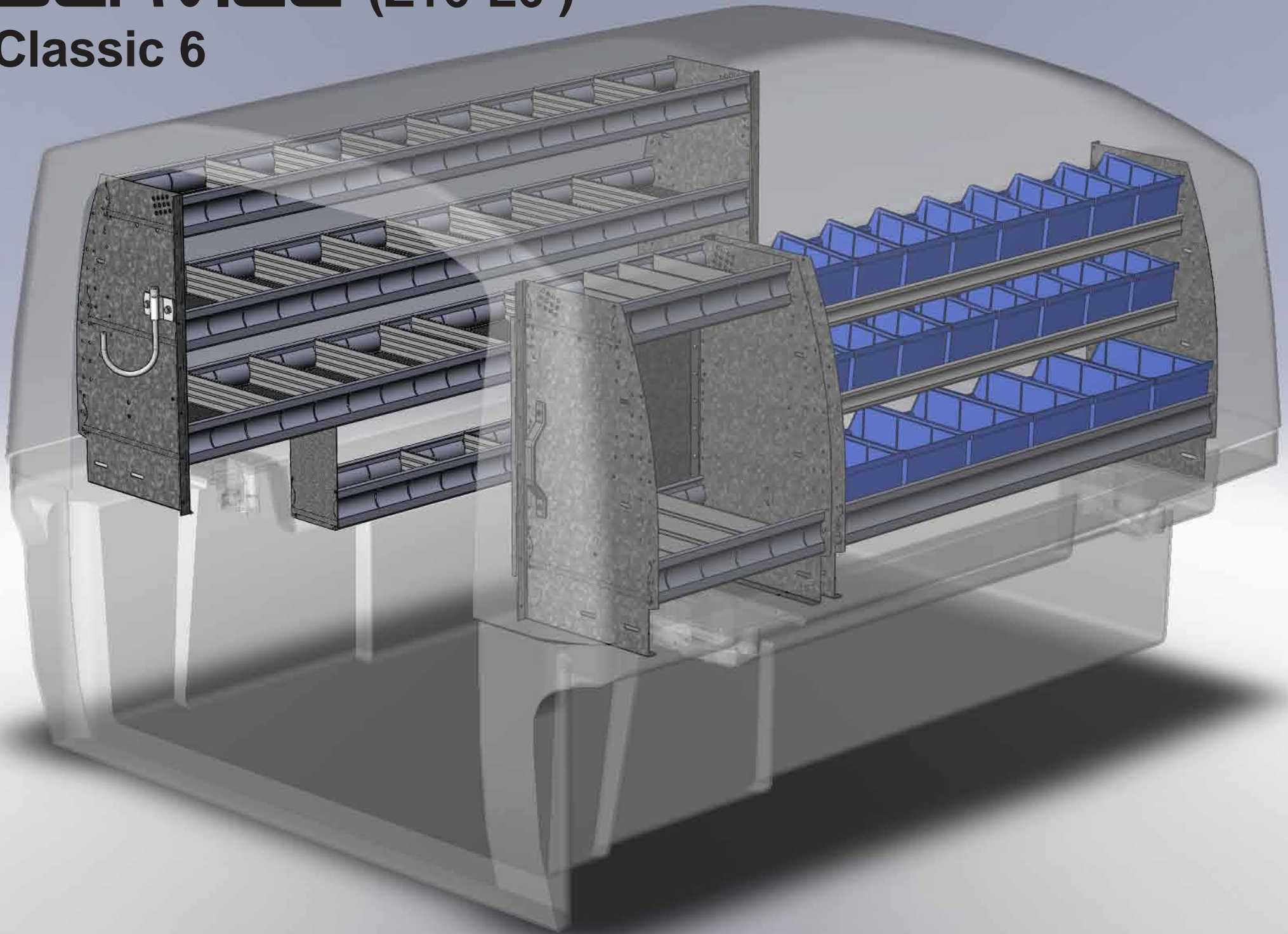
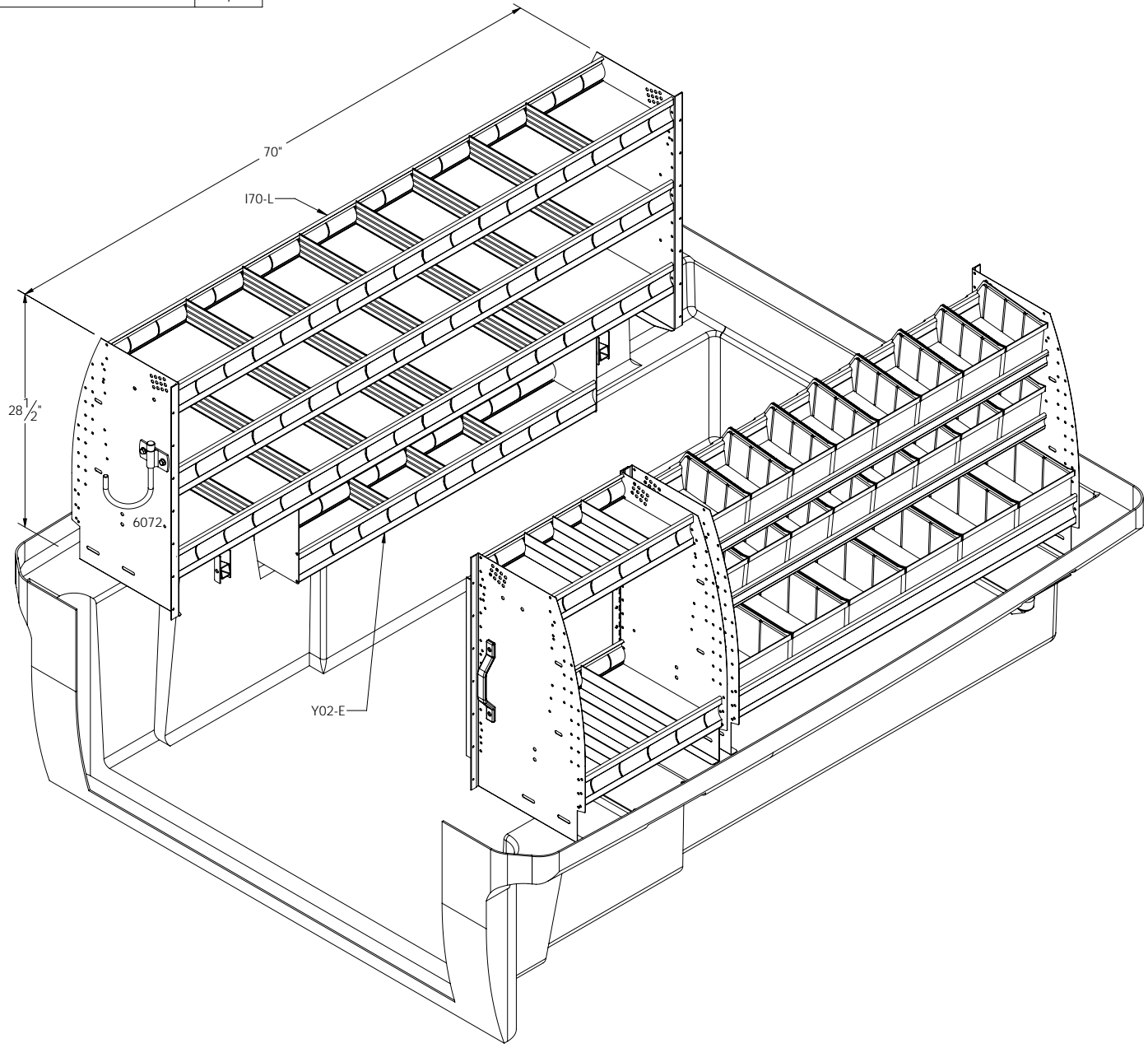

TABLE DE NOMENCLATURE / BOM TABLE		
No	DESCRIPTION	QTE/QTY
I70-L	CONTOURED SHELF UNIT, 3 DIVIDED SHELVES - 70"W X 28-1/2"H	1
6072	SWIVEL HOOK	1
Y02-E	HALF SHELF - 6"D X 42"W	1
M48-L	CONTOURED BIN UNIT, 3 SHELVES, 48"W X 28-1/2"H	1
S20-L	LOCKER, TWO DIVIDED SHELVES, 20"W X 28-1/2"H	1
6093	PLASTIC GRAB HANDLE 9-1/2"	1



SPACEKAP CLASSIC 6'

**RANGER DESIGN**  
**SPACEKAP**

PROPRIETARY AND CONFIDENTIAL  
 THE INFORMATION CONTAINED IN THIS DRAWING IS THE SOLE  
 PROPERTY OF RANGER DESIGN INC. ANY REPRODUCTION IN PART  
 OR AS A WHOLE WITHOUT THE WRITTEN PERMISSION OF  
 RANGER DESIGN INC IS PROHIBITED.

TITLE: ENSEMBLE POUR SERVICE  
 SERVICE PACKAGE

SIZE <b>C</b>	DWG. NO. Z16-L6	REV 0
2010-04-30	SCALE: 1:8	SHEET 1 OF 2



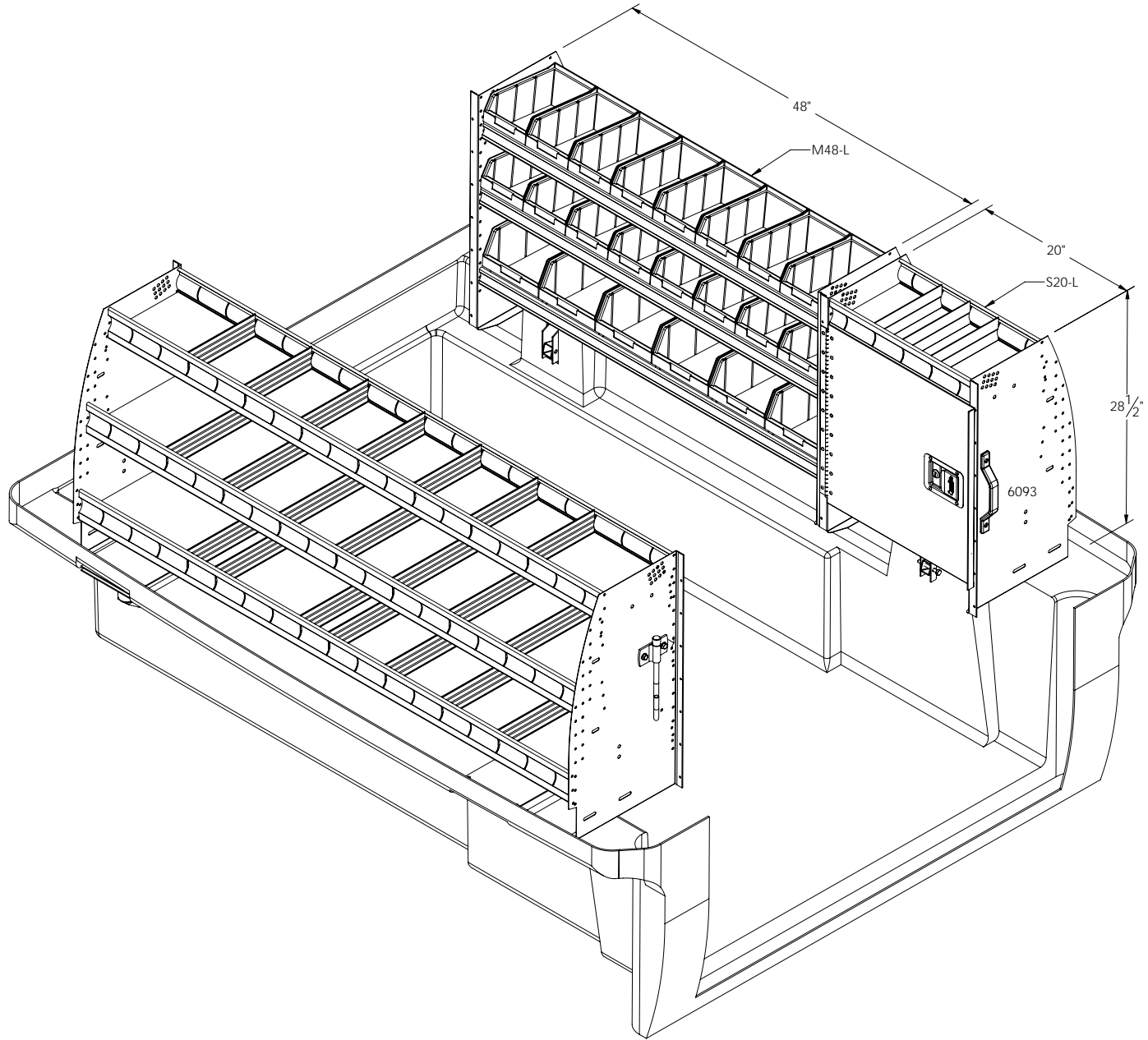

PROPRIETARY AND CONFIDENTIAL  
THE INFORMATION CONTAINED IN THIS DRAWING IS THE SOLE  
PROPERTY OF RANGER DESIGN INC. ANY REPRODUCTION IN PART  
OR AS A WHOLE WITHOUT THE WRITTEN PERMISSION OF  
RANGER DESIGN INC IS PROHIBITED.

TITLE:  
ENSEMBLE POUR SERVICE  
SERVICE PACKAGE

SIZE <b>C</b>	DWG. NO. Z16-L6	REV 0
2010-04-30	SCALE: 1:8	SHEET 2 OF 2

# WORK STATION (Z17-L6)

Classic 6

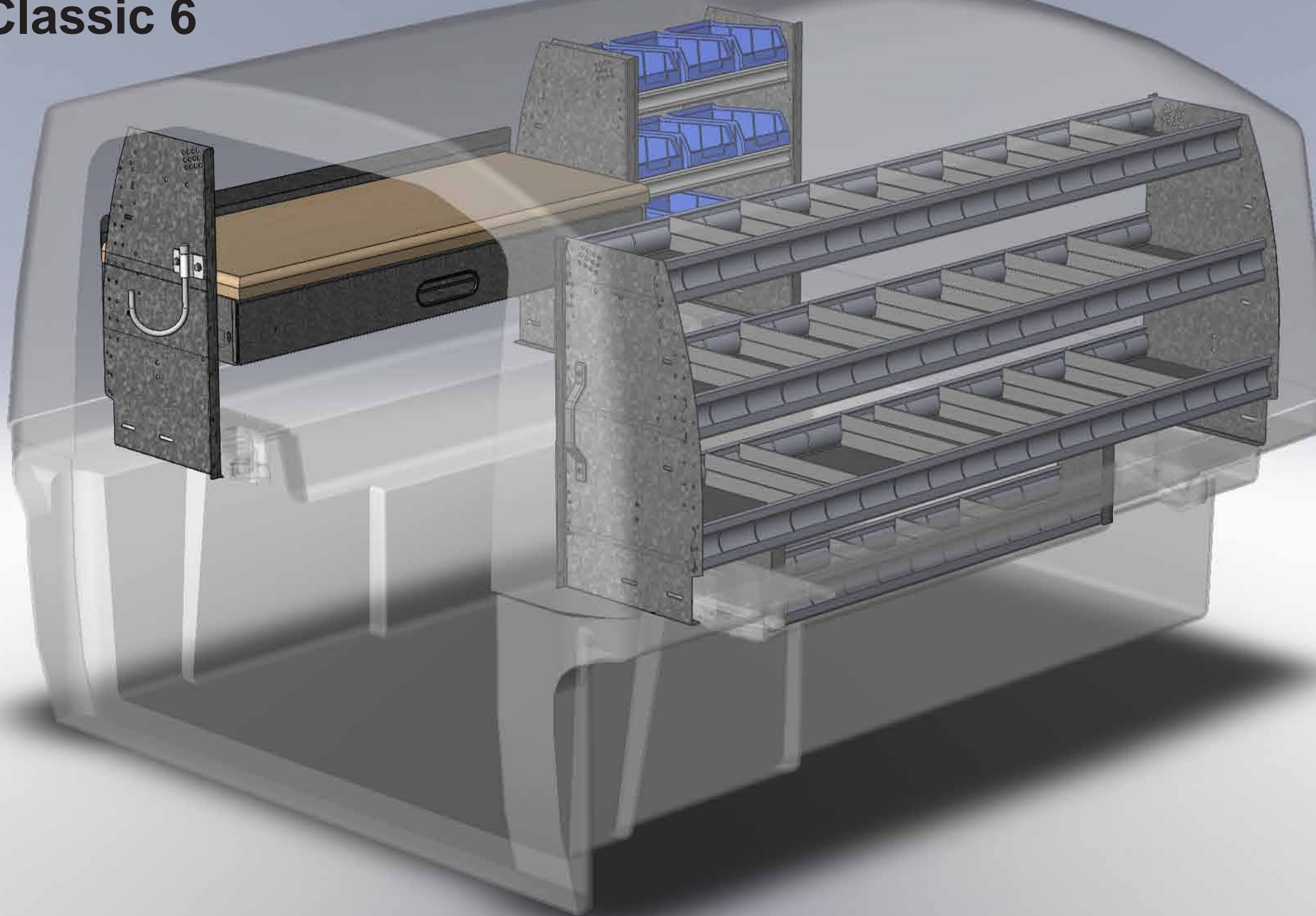
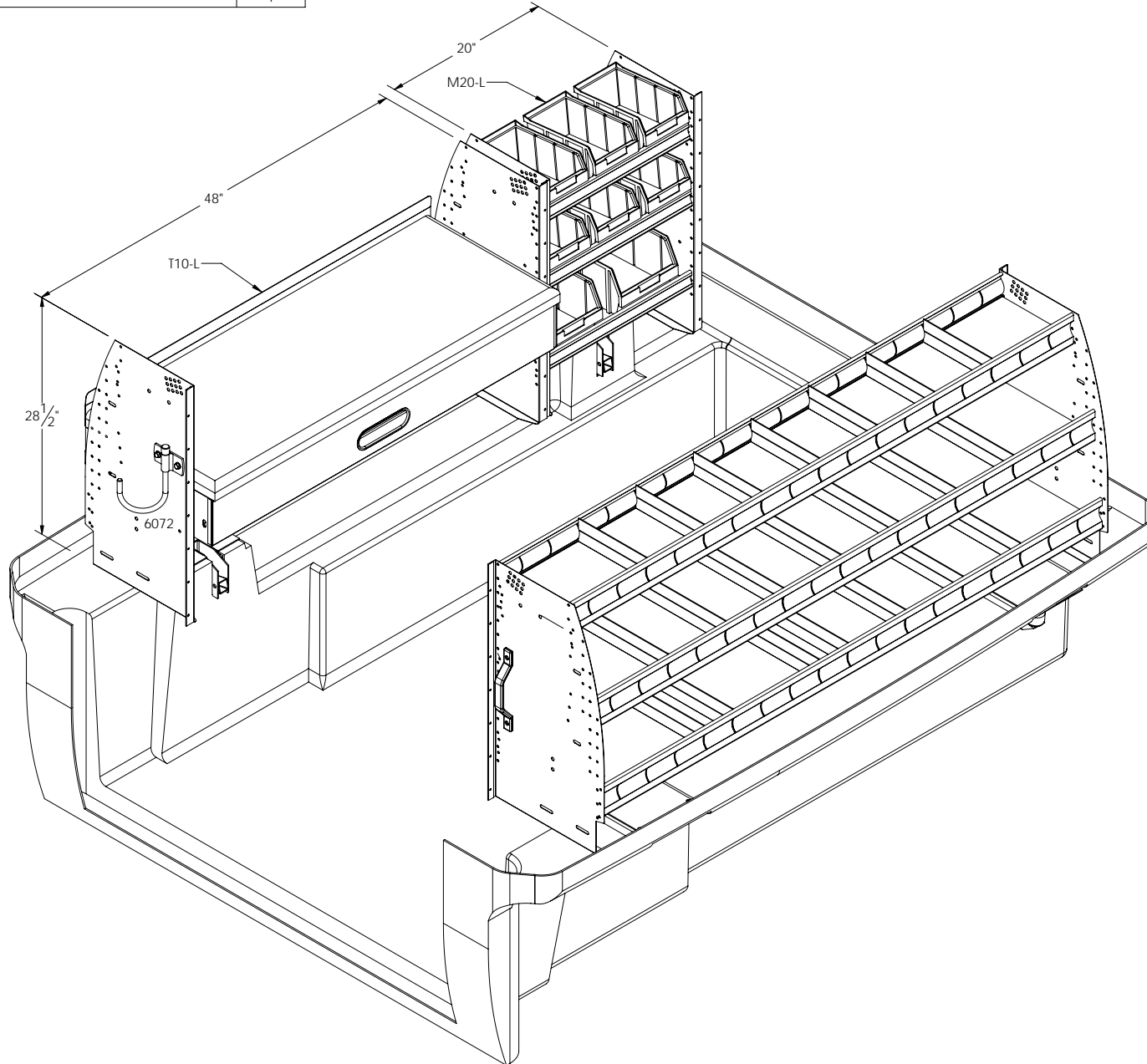

TABLE DE NOMENCLATURE / BOM TABLE		
No	DESCRIPTION	QTE/QTY
M20-L	CONTOURED BIN UNIT, 3 SHELVES, 20"W X 28-1/2"H	1
T10-L	WORKBENCH WITH PULL OUT DRAWER, 18"D X 48"W	1
6072	SWIVEL HOOK	1
I70-L	CONTOURED SHELF UNIT, 3 DIVIDED SHELVES - 70"W X 28-1/2"H	1
Y02-E	HALF SHELF - 6"D X 42"W	1
6093	PLASTIC GRAB HANDLE 9-1/2"	1



SPACEKAP CLASSIC 6'



PROPRIETARY AND CONFIDENTIAL  
THE INFORMATION CONTAINED IN THIS DRAWING IS THE SOLE  
PROPERTY OF RANGER DESIGN INC. ANY REPRODUCTION IN PART  
OR AS A WHOLE WITHOUT THE WRITTEN PERMISSION OF  
RANGER DESIGN INC IS PROHIBITED.

TITLE: ENSEMBLE ATELIER  
WORKSTATION PACKAGE

SIZE <b>C</b>	DWG. NO. Z17-L6	REV 0
2010-04-30	SCALE: 1:8	SHEET 1 OF 2

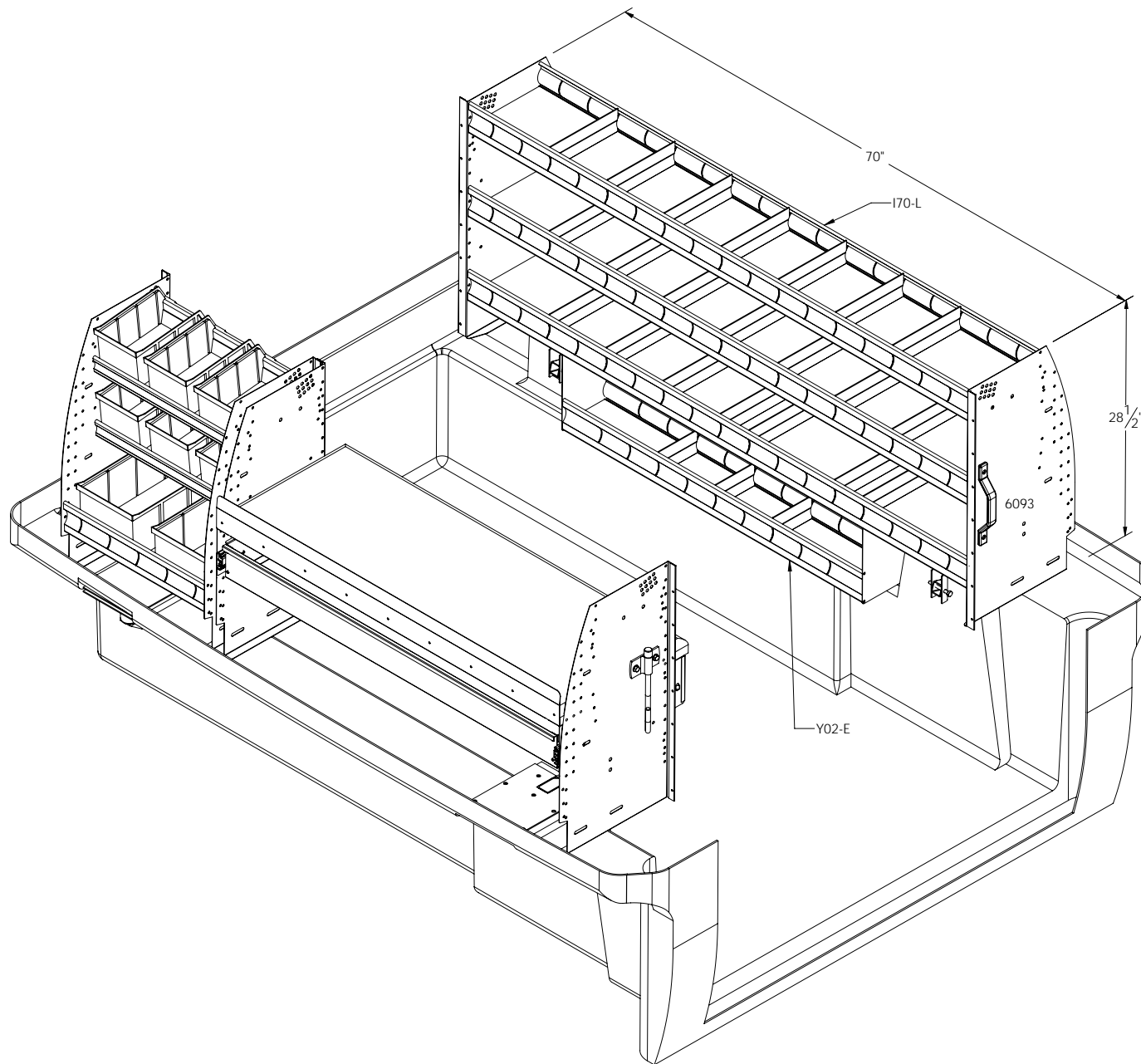

PROPRIETARY AND CONFIDENTIAL  
 THE INFORMATION CONTAINED IN THIS DRAWING IS THE SOLE  
 PROPERTY OF RANGER DESIGN INC. ANY REPRODUCTION IN PART  
 OR AS A WHOLE WITHOUT THE WRITTEN PERMISSION OF  
 RANGER DESIGN INC IS PROHIBITED.

TITLE: ENSEMBLE ATELIER  
 WORKSTATION PACKAGE

SIZE <b>C</b>	DWG. NO. Z17-L6	REV 0
2010-04-30	SCALE: 1:8	SHEET 2 OF 2

# CONTRACTOR (Z10-L8)

Classic 8

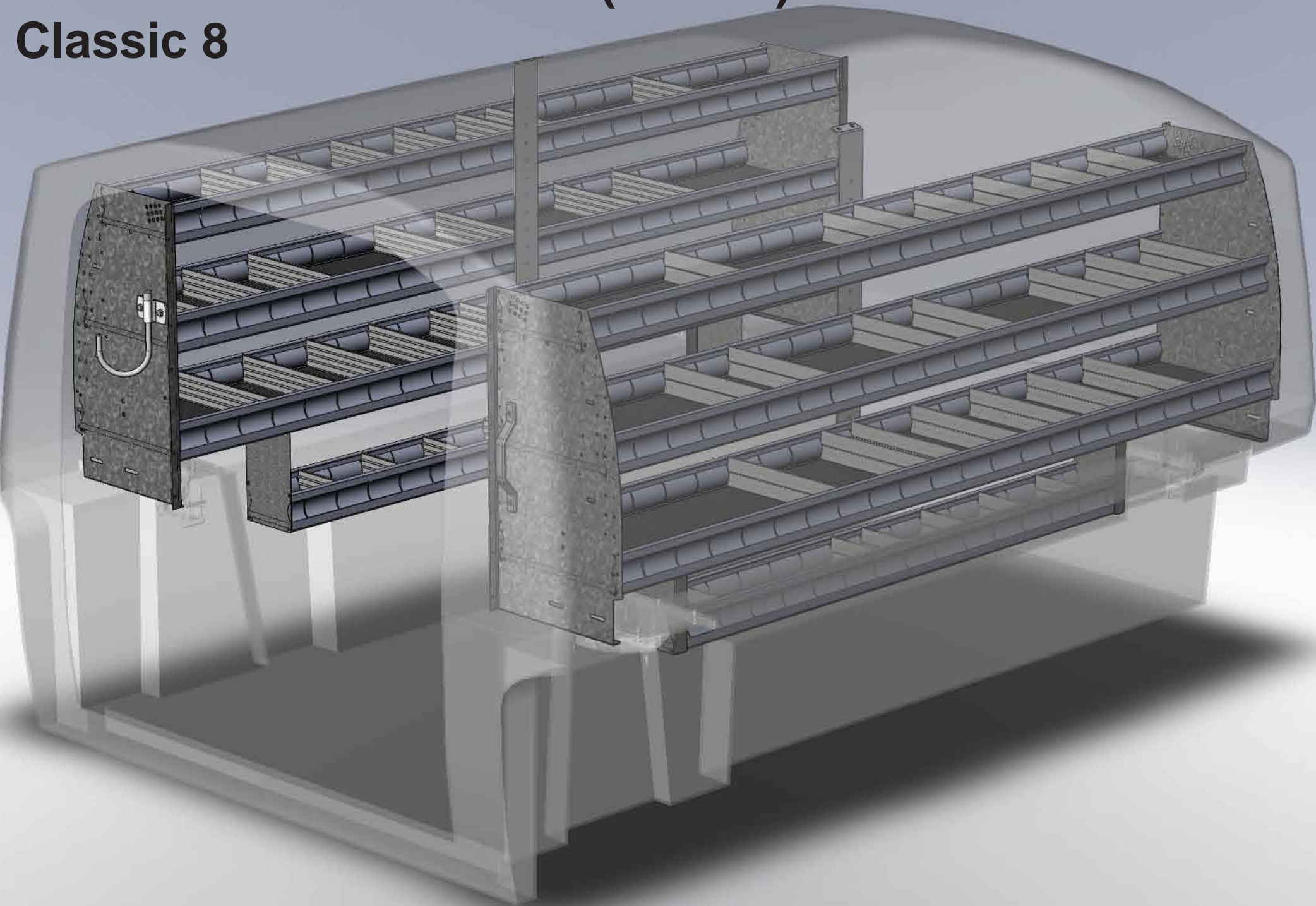
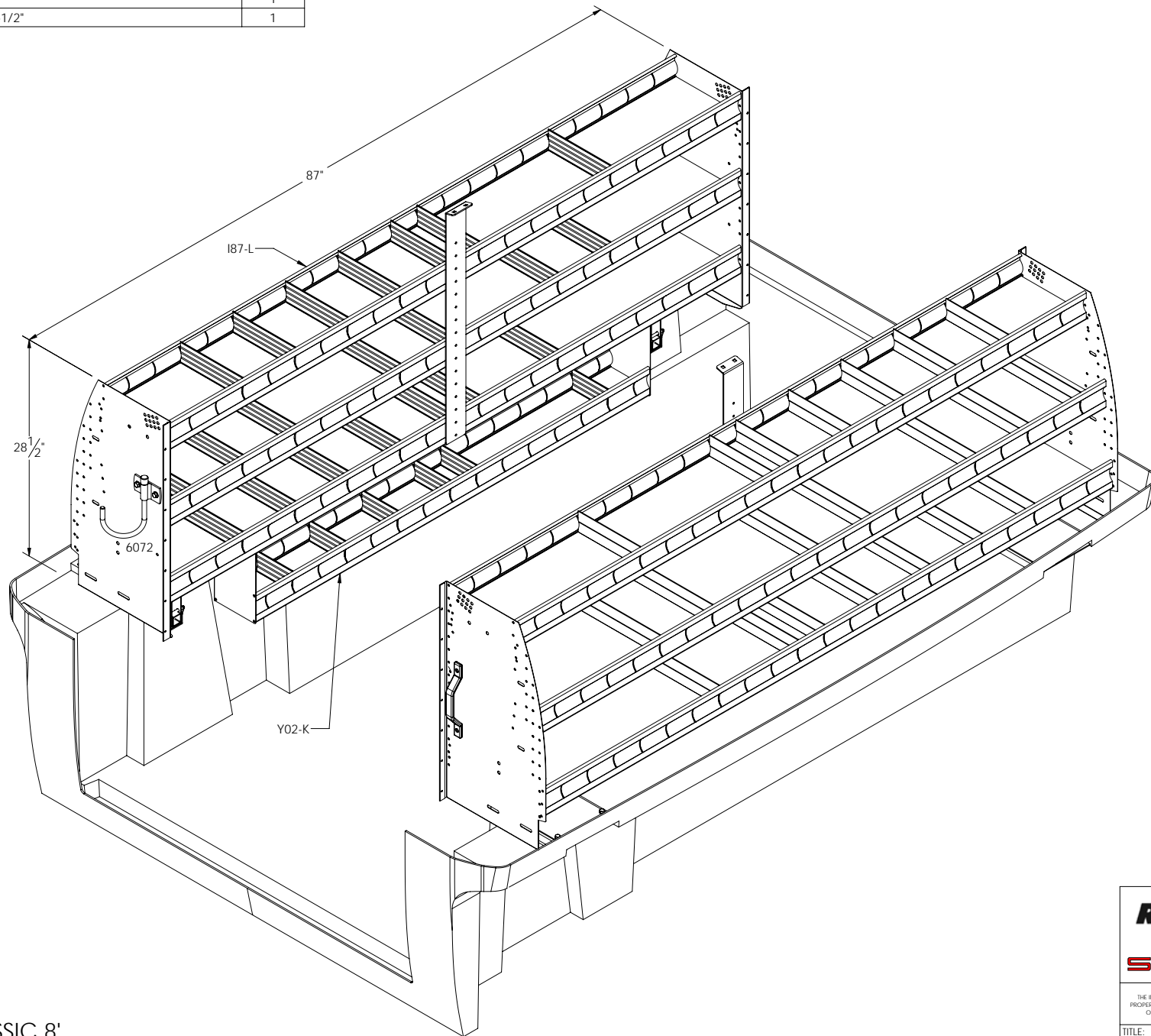

TABLE DE NOMENCLATURE / BOM TABLE		
No	DESCRIPTION	QTE/QTY.
187-L	CONTOURED SHELF UNIT, 3 DIVIDED SHELVES - 87"W X 28-1/2"H	2
Y02-K	HALF SHELF - 6"D X 60"W	2
6072	SWIVEL HOOK	1
6093	PLASTIC GRAB HANDLE 9-1/2"	1



SPACEKAP CLASSIC 8'



PROPRIETARY AND CONFIDENTIAL  
THE INFORMATION CONTAINED IN THIS DRAWING IS THE SOLE  
PROPERTY OF RANGER DESIGN INC. ANY REPRODUCTION IN PART  
OR AS A WHOLE WITHOUT THE WRITTEN PERMISSION OF  
RANGER DESIGN INC IS PROHIBITED.

TITLE:  
ENSEMBLE POUR CONTRACTEURS  
CONTRACTORS PACKAGE

SIZE <b>C</b>	DWG. NO. Z10-L8	REV 0
------------------	--------------------	----------

2010-04-29 SCALE: 1:8 SHEET 1 OF 2

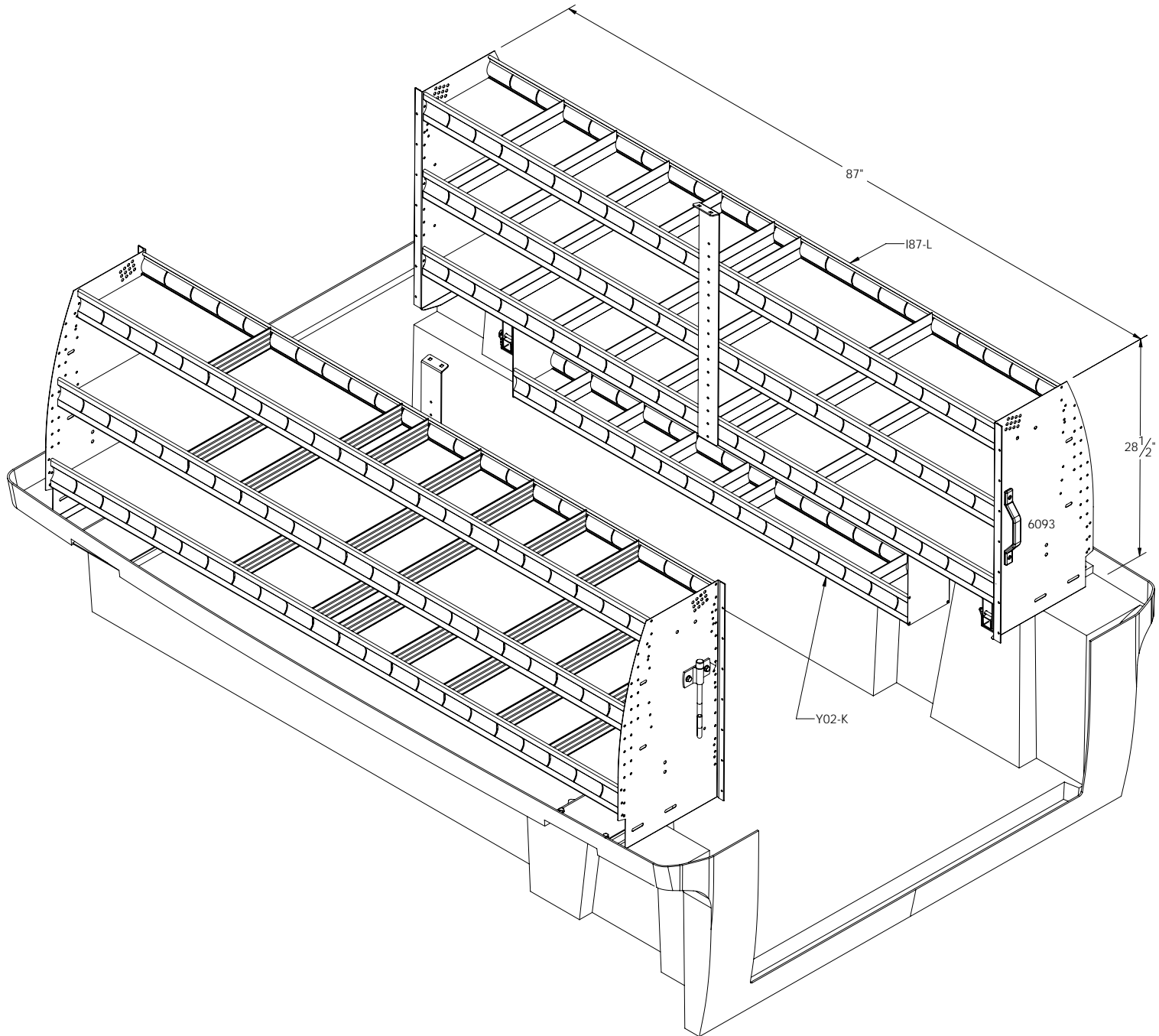

PROPRIETARY AND CONFIDENTIAL  
 THE INFORMATION CONTAINED IN THIS DRAWING IS THE SOLE  
 PROPERTY OF RANGER DESIGN INC. ANY REPRODUCTION IN PART  
 OR AS A WHOLE WITHOUT THE WRITTEN PERMISSION OF  
 RANGER DESIGN INC IS PROHIBITED.

TITLE:  
 ENSEMBLE POUR CONTRACTEURS  
 CONTRACTORS PACKAGE

SIZE <b>C</b>	DWG. NO. Z10-L8	REV 0
------------------	--------------------	----------

# PLUMBER / ELECTRICIAN (Z15-L8)

Classic 8

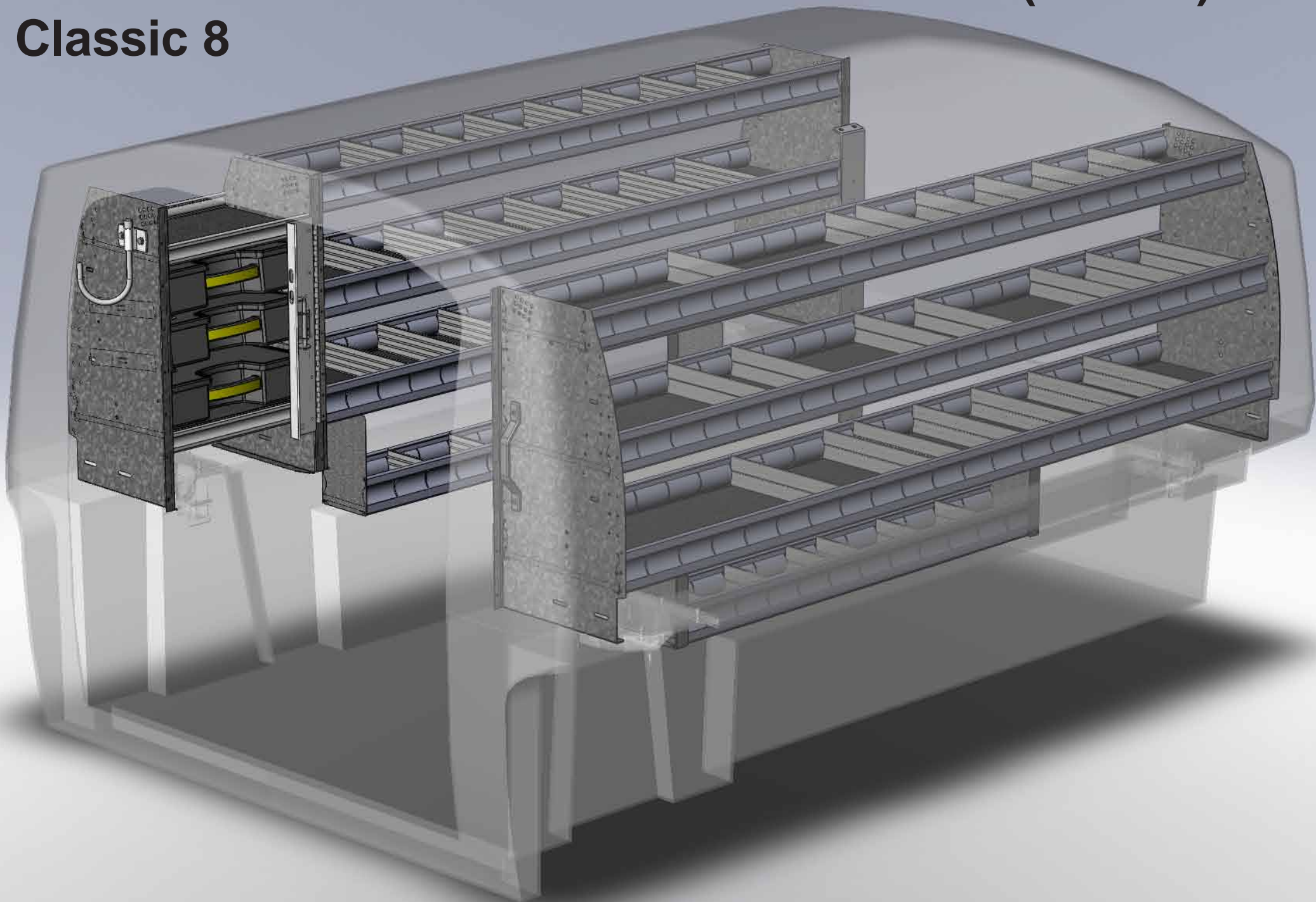
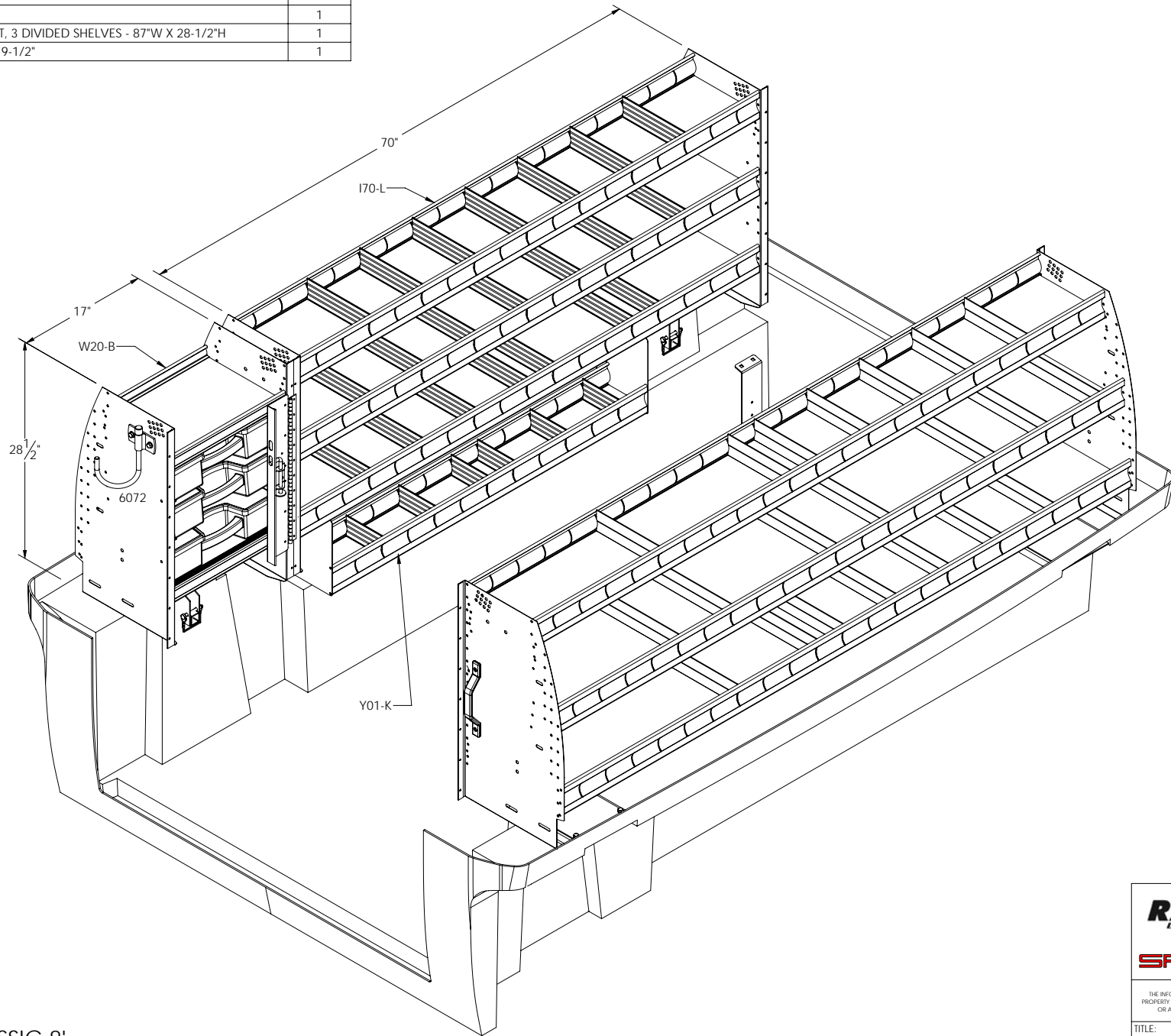



TABLE DE NOMENCLATURE / BOM TABLE		
No	DESCRIPTION	QTE/QTY.
I70-L	CONTOURED SHELF UNIT, 3 DIVIDED SHELVES - 70"W X 28-1/2"H	1
W20-B	PARTSKEEPER CABINET W 3 CASES AND 1 SHELF - 17"W X 28-1/2"H	1
Y01-K	HALF SHELF - 6"D X 48"W	2
6072	SWIVEL HOOK	1
I87-L	CONTOURED SHELF UNIT, 3 DIVIDED SHELVES - 87"W X 28-1/2"H	1
6093	PLASTIC GRAB HANDLE 9-1/2"	1



SPACEKAP CLASSIC 8'

**RANGER DESIGN**  
**SPACEKAP**

PROPRIETARY AND CONFIDENTIAL  
 THE INFORMATION CONTAINED IN THIS DRAWING IS THE SOLE  
 PROPERTY OF RANGER DESIGN INC. ANY REPRODUCTION IN PART  
 OR AS A WHOLE WITHOUT THE WRITTEN PERMISSION OF  
 RANGER DESIGN INC IS PROHIBITED.

TITLE:  
 ENSEMBLE POUR PLOMBIERS  
 PLUMBERS PACKAGE

SIZE <b>C</b>	DWG. NO. Z15-L8	REV 0
2010-04-29	SCALE: 1:8	SHEET 1 OF 2

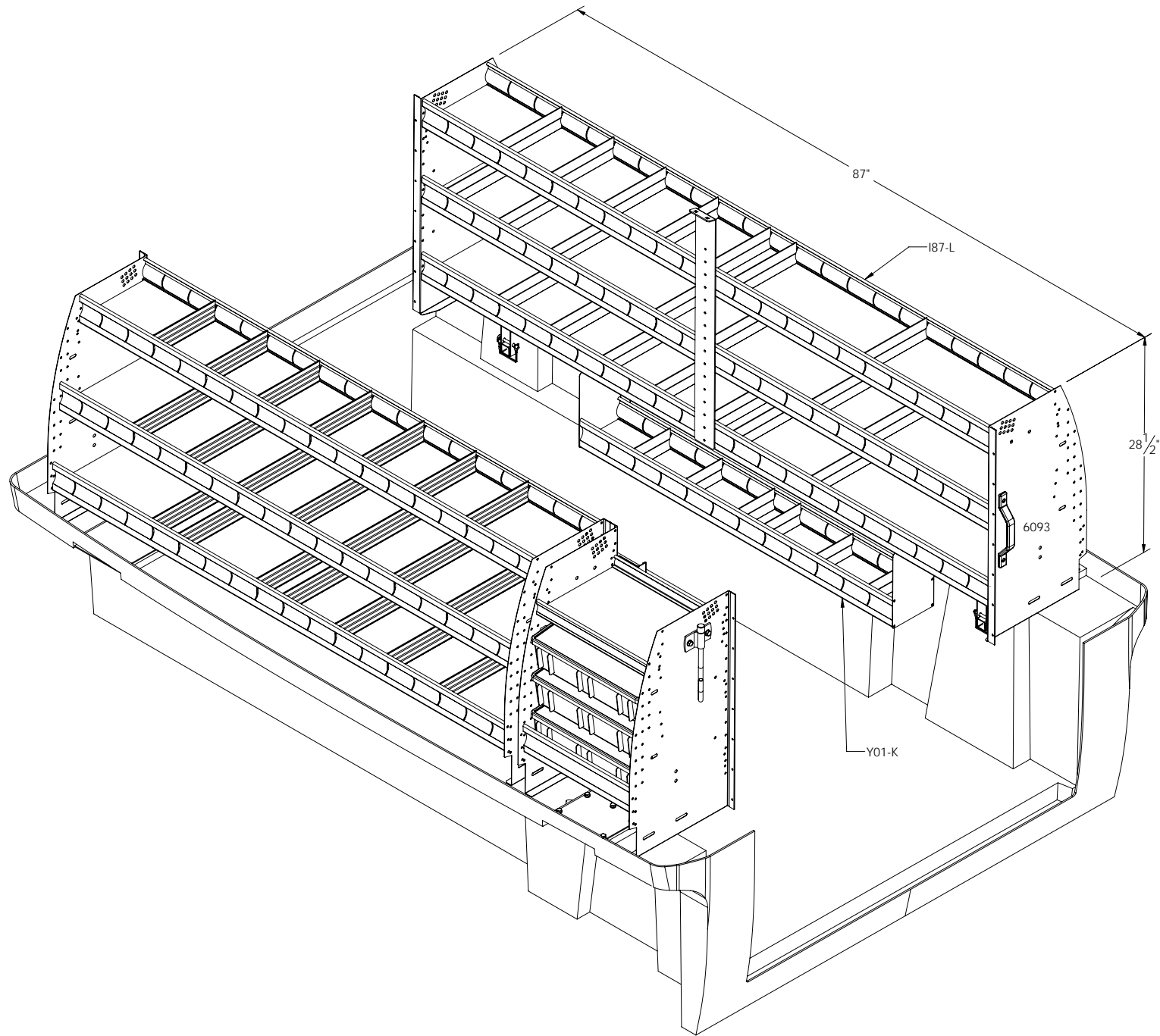

PROPRIETARY AND CONFIDENTIAL  
 THE INFORMATION CONTAINED IN THIS DRAWING IS THE SOLE  
 PROPERTY OF RANGER DESIGN INC. ANY REPRODUCTION IN PART  
 OR AS A WHOLE WITHOUT THE WRITTEN PERMISSION OF  
 RANGER DESIGN INC IS PROHIBITED.

TITLE:  
 ENSEMBLE POUR PLOMBIERS  
 PLUMBERS PACKAGE

SIZE <b>C</b>	DWG. NO. Z15-L8	REV 0
------------------	--------------------	----------

# SERVICE (Z16-L8)

## Classic 8

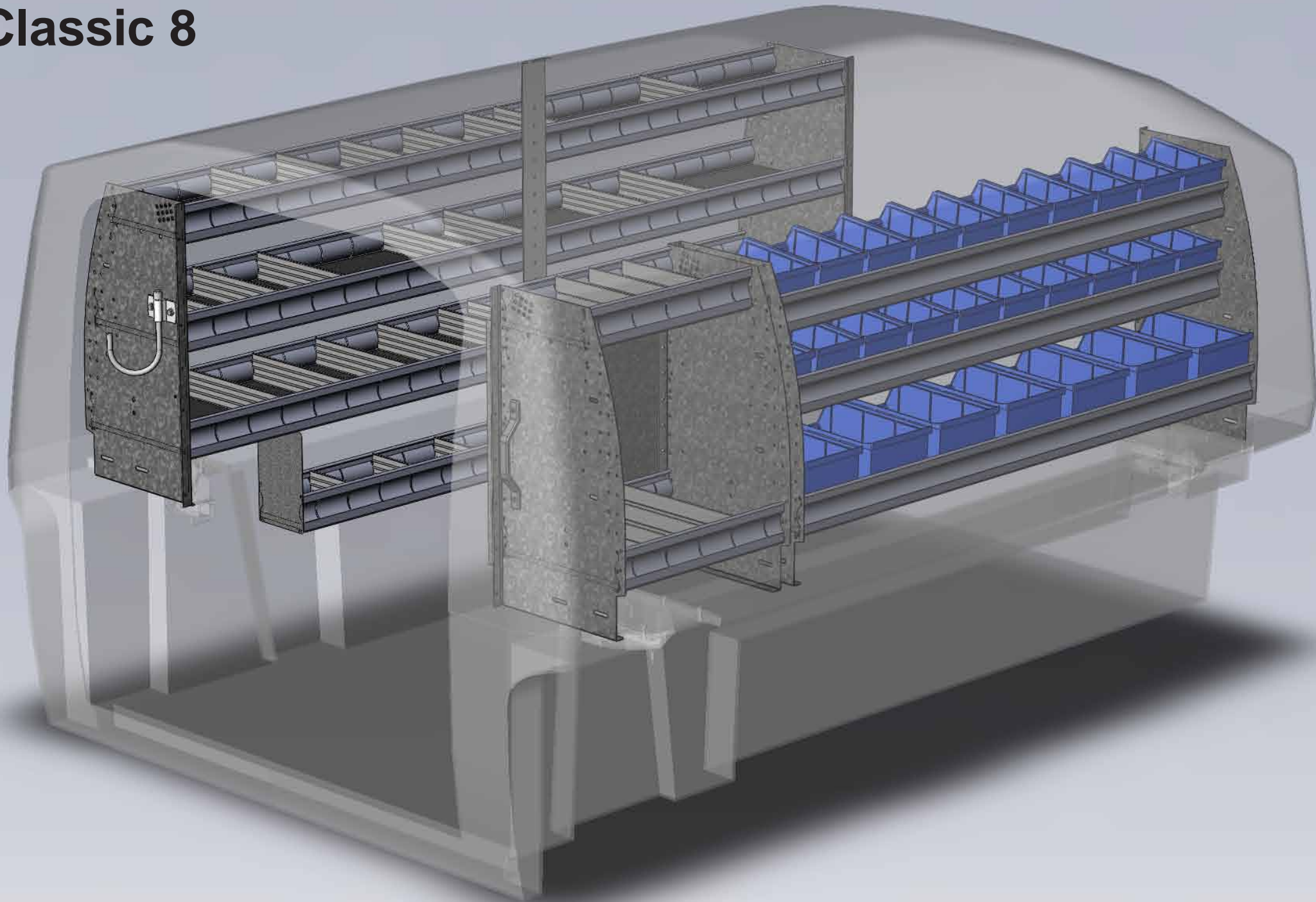
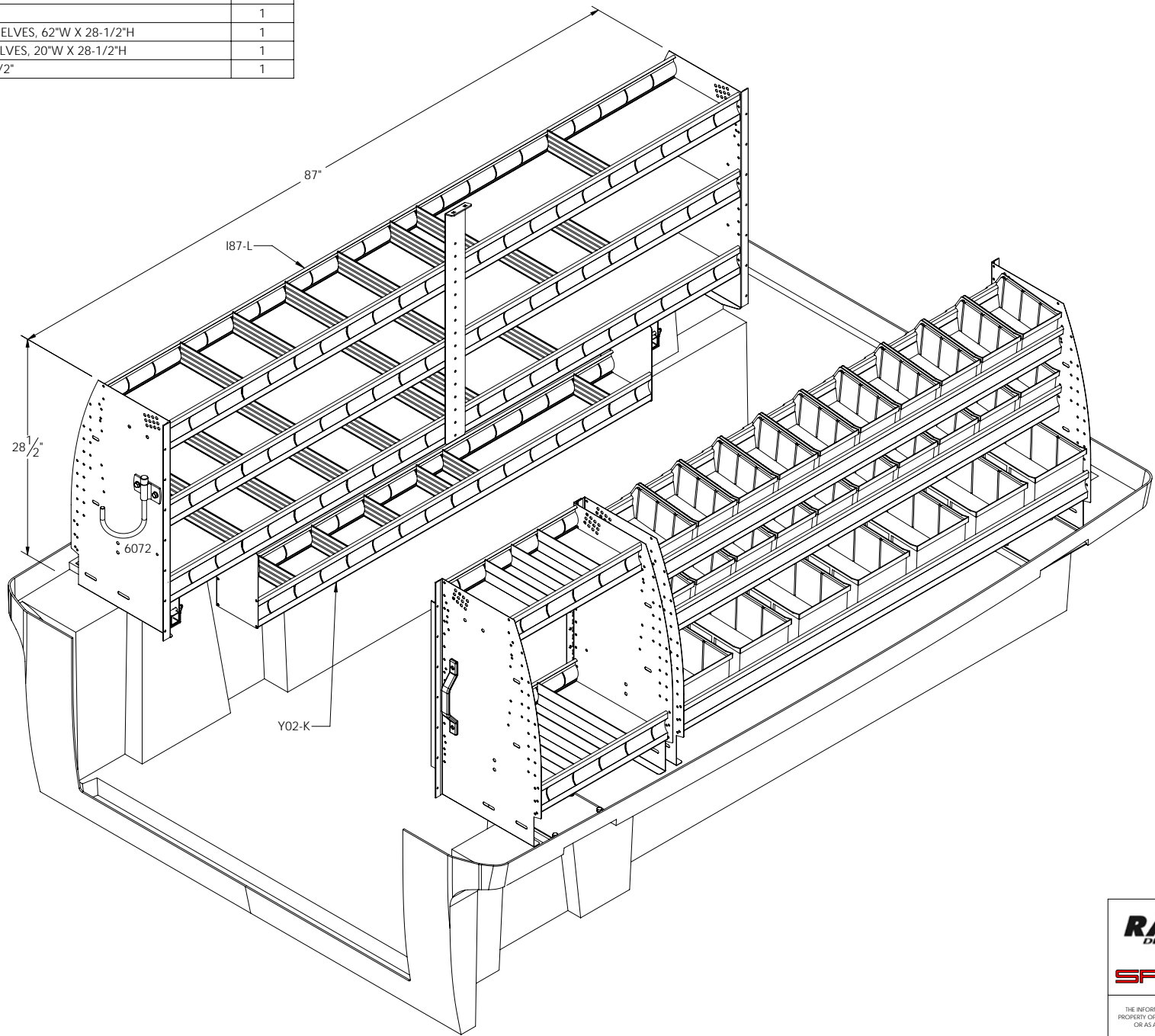

TABLE DE NOMENCLATURE / BOM TABLE		
No	DESCRIPTION	QTE/QTY
I87-L	CONTOURED SHELF UNIT, 3 DIVIDED SHELVES - 87"W X 28-1/2"H	1
Y02-K	HALF SHELF - 6"D X 60"W	1
6072	SWIVEL HOOK	1
M62-L	CONTOURED BIN UNIT, 3 SHELVES, 62"W X 28-1/2"H	1
S20-L	LOCKER, TWO DIVIDED SHELVES, 20"W X 28-1/2"H	1
6093	PLASTIC GRAB HANDLE 9-1/2"	1



SPACEKAP CLASSIC 8'

**RANGER DESIGN**  
**SPACEKAP**

PROPRIETARY AND CONFIDENTIAL  
 THE INFORMATION CONTAINED IN THIS DRAWING IS THE SOLE PROPERTY OF RANGER DESIGN INC. ANY REPRODUCTION IN PART OR AS A WHOLE WITHOUT THE WRITTEN PERMISSION OF RANGER DESIGN INC IS PROHIBITED.

TITLE: ENSEMBLE POUR SERVICE SERVICE PACKAGE

SIZE <b>C</b>	DWG. NO. Z16-L8	REV 0
2010-04-29	SCALE: 1:8	SHEET 1 OF 2

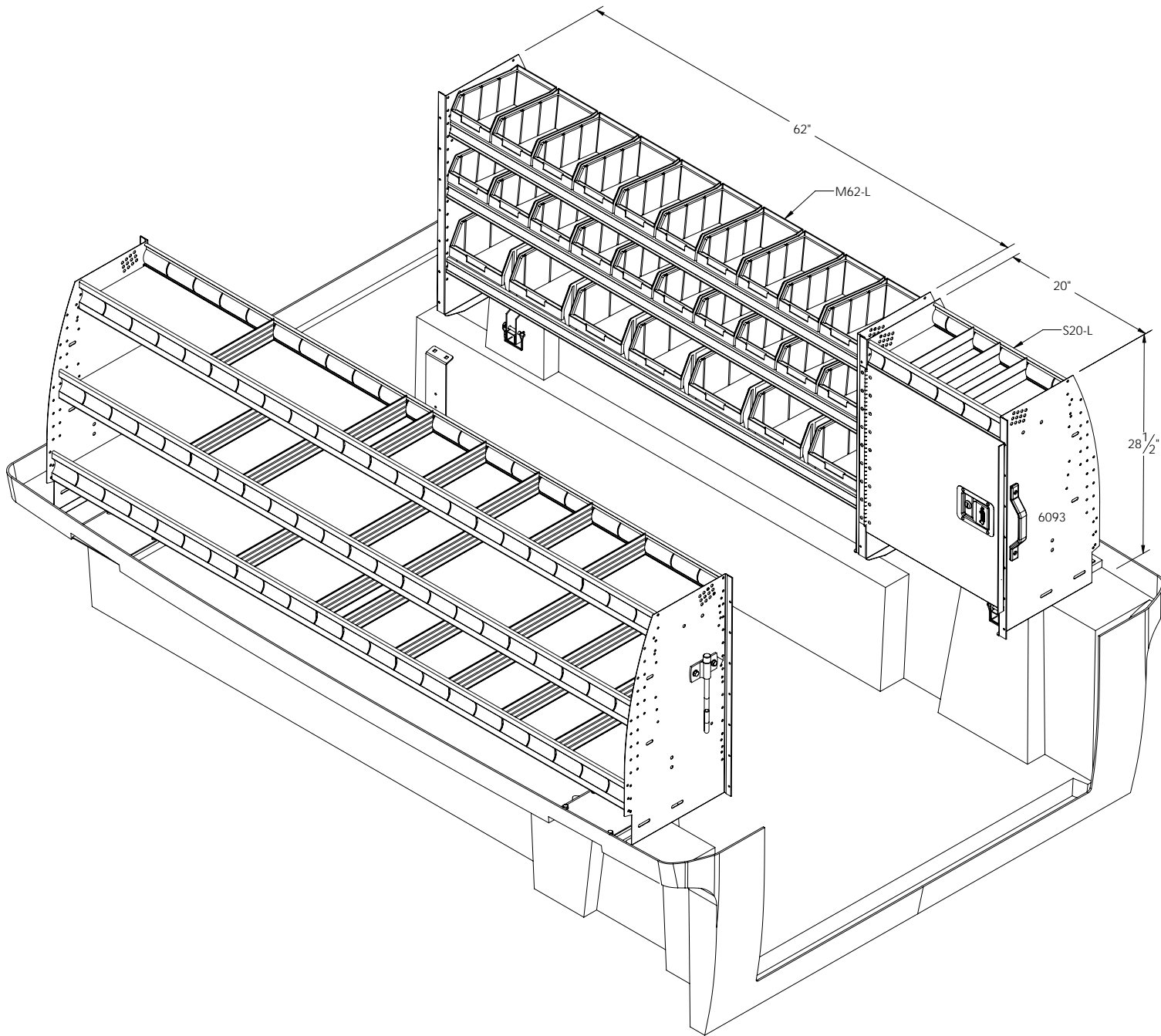

PROPRIETARY AND CONFIDENTIAL  
 THE INFORMATION CONTAINED IN THIS DRAWING IS THE SOLE  
 PROPERTY OF RANGER DESIGN INC. ANY REPRODUCTION IN PART  
 OR AS A WHOLE WITHOUT THE WRITTEN PERMISSION OF  
 RANGER DESIGN INC IS PROHIBITED.

TITLE:  
 ENSEMBLE POUR SERVICE  
 SERVICE PACKAGE

SIZE <b>C</b>	DWG. NO. Z16-L8	REV 0
2010-04-29	SCALE: 1:8	SHEET 2 OF 2

# WORK STATION (Z17-L8)

Classic 8

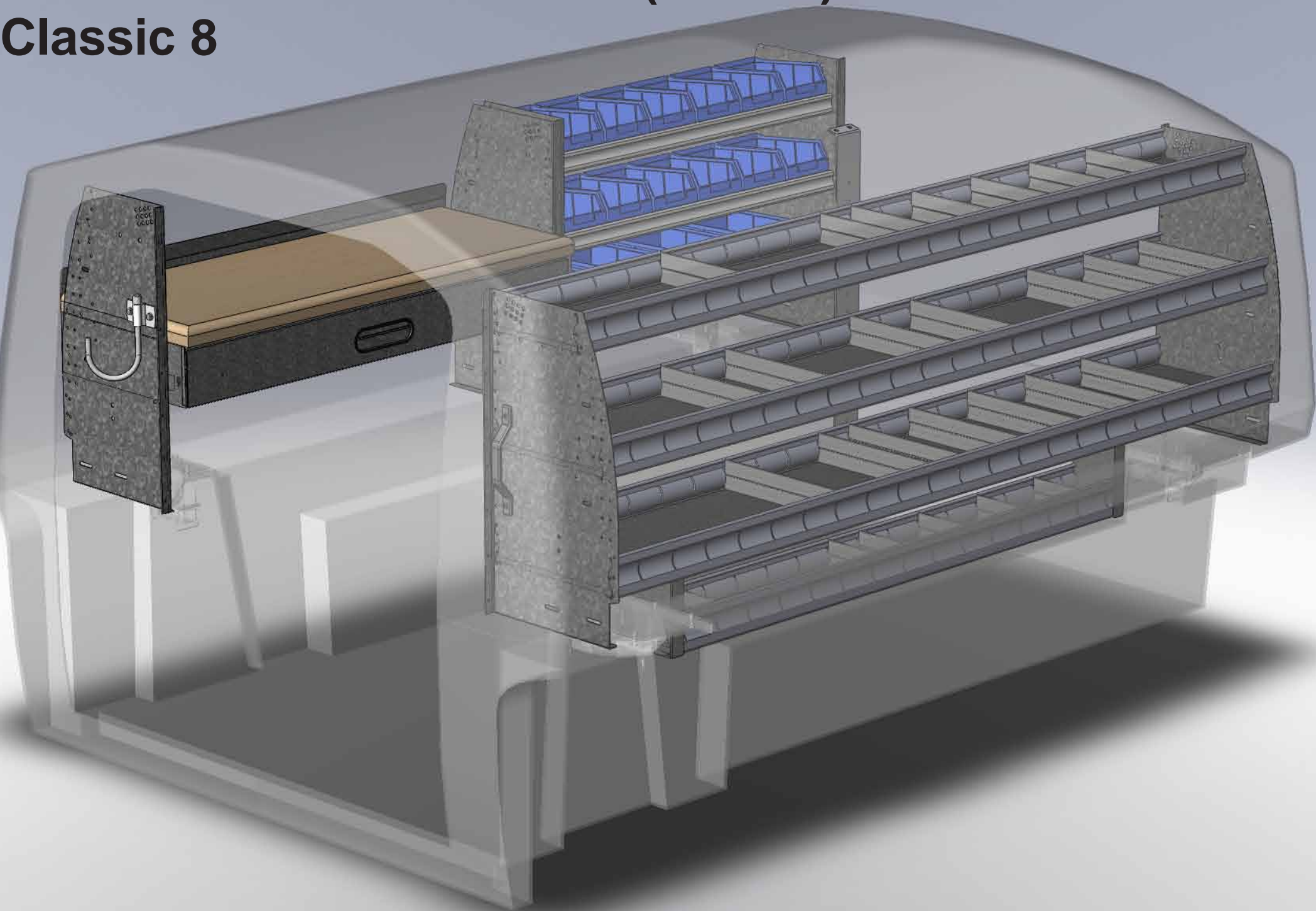
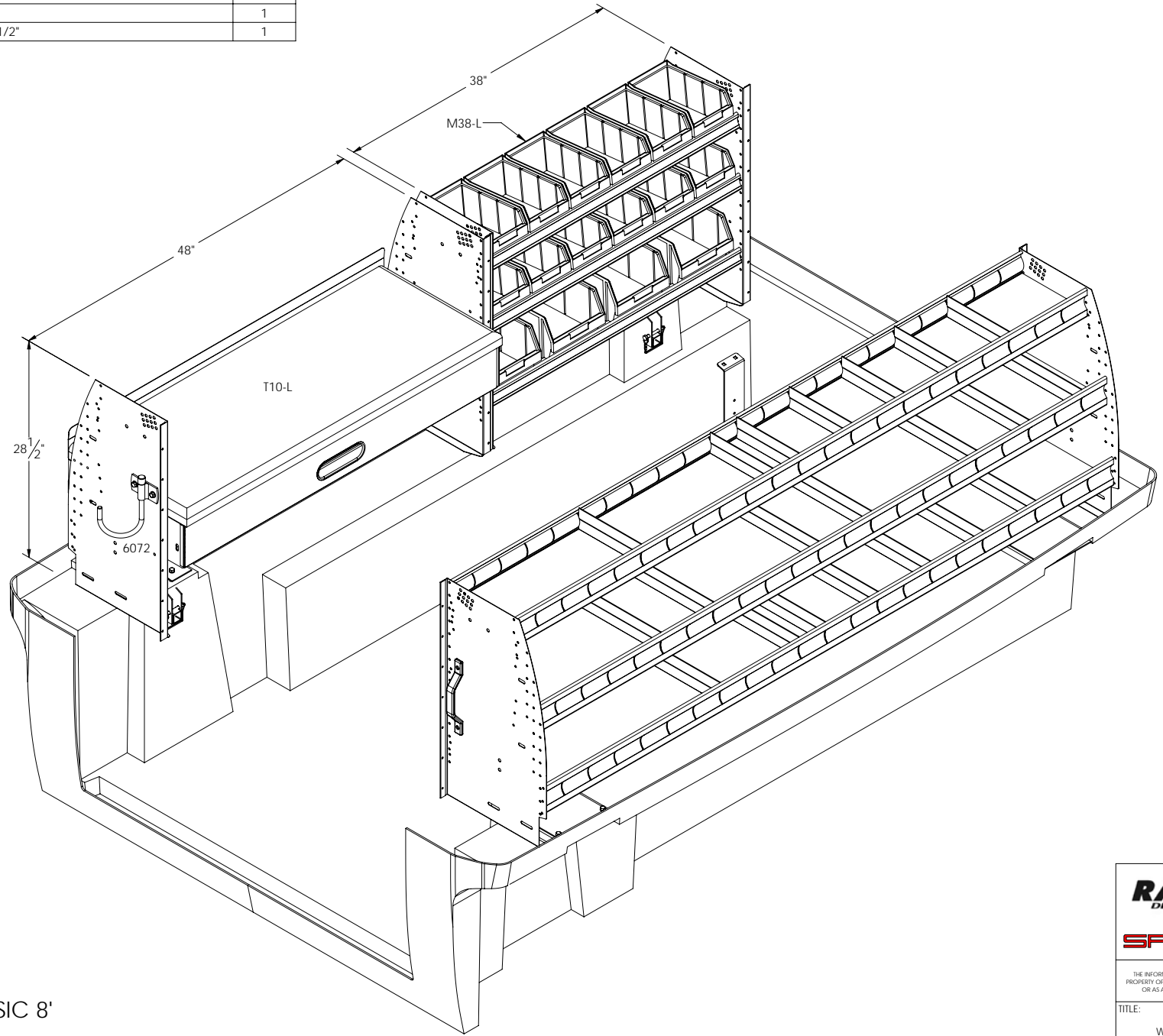

TABLE DE NOMENCLATURE / BOM TABLE		
No	DESCRIPTION	QTE/QTY.
M38-L	CONTOURED BIN UNIT, 3 SHELVES, 38"W X 28-1/2"H	1
T10-L	WORKBENCH WITH PULL OUT DRAWER, 18"D X 48"W	1
6072	SWIVEL HOOK	1
I87-L	CONTOURED SHELF UNIT, 3 DIVIDED SHELVES - 87"W X 28-1/2"H	1
Y02-K	HALF SHELF - 6"D X 60"W	1
6093	PLASTIC GRAB HANDLE 9-1/2"	1



SPACEKAP CLASSIC 8'

**RANGER DESIGN**  
**SPACEKAP**

PROPRIETARY AND CONFIDENTIAL  
 THE INFORMATION CONTAINED IN THIS DRAWING IS THE SOLE PROPERTY OF RANGER DESIGN INC. ANY REPRODUCTION IN PART OR AS A WHOLE WITHOUT THE WRITTEN PERMISSION OF RANGER DESIGN INC IS PROHIBITED.

TITLE: ENSEMBLE ATELIER  
 WORKSTATION PACKAGE

SIZE <b>C</b>	DWG. NO. Z17-L8	REV 0
2010-04-30	SCALE: 1:8	SHEET 1 OF 2

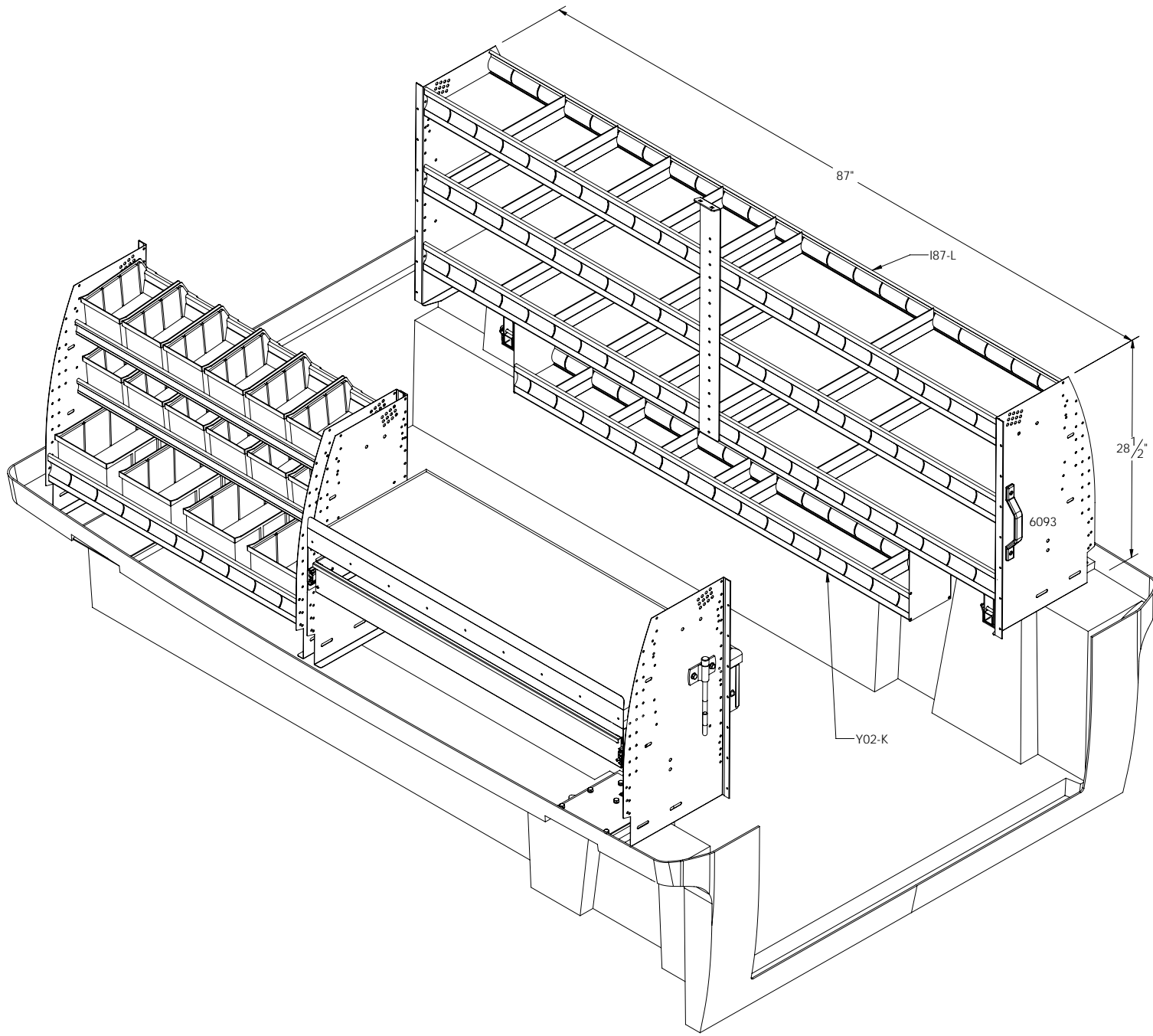

PROPRIETARY AND CONFIDENTIAL  
 THE INFORMATION CONTAINED IN THIS DRAWING IS THE SOLE  
 PROPERTY OF RANGER DESIGN INC. ANY REPRODUCTION IN PART  
 OR AS A WHOLE WITHOUT THE WRITTEN PERMISSION OF  
 RANGER DESIGN INC IS PROHIBITED.

TITLE: ENSEMBLE ATELIER  
 WORKSTATION PACKAGE

SIZE <b>C</b>	DWG. NO. Z17-L8	REV 0
2010-04-30	SCALE: 1:8	SHEET 2 OF 2



# CONTRACTOR (Z10-K6)

Plus 6

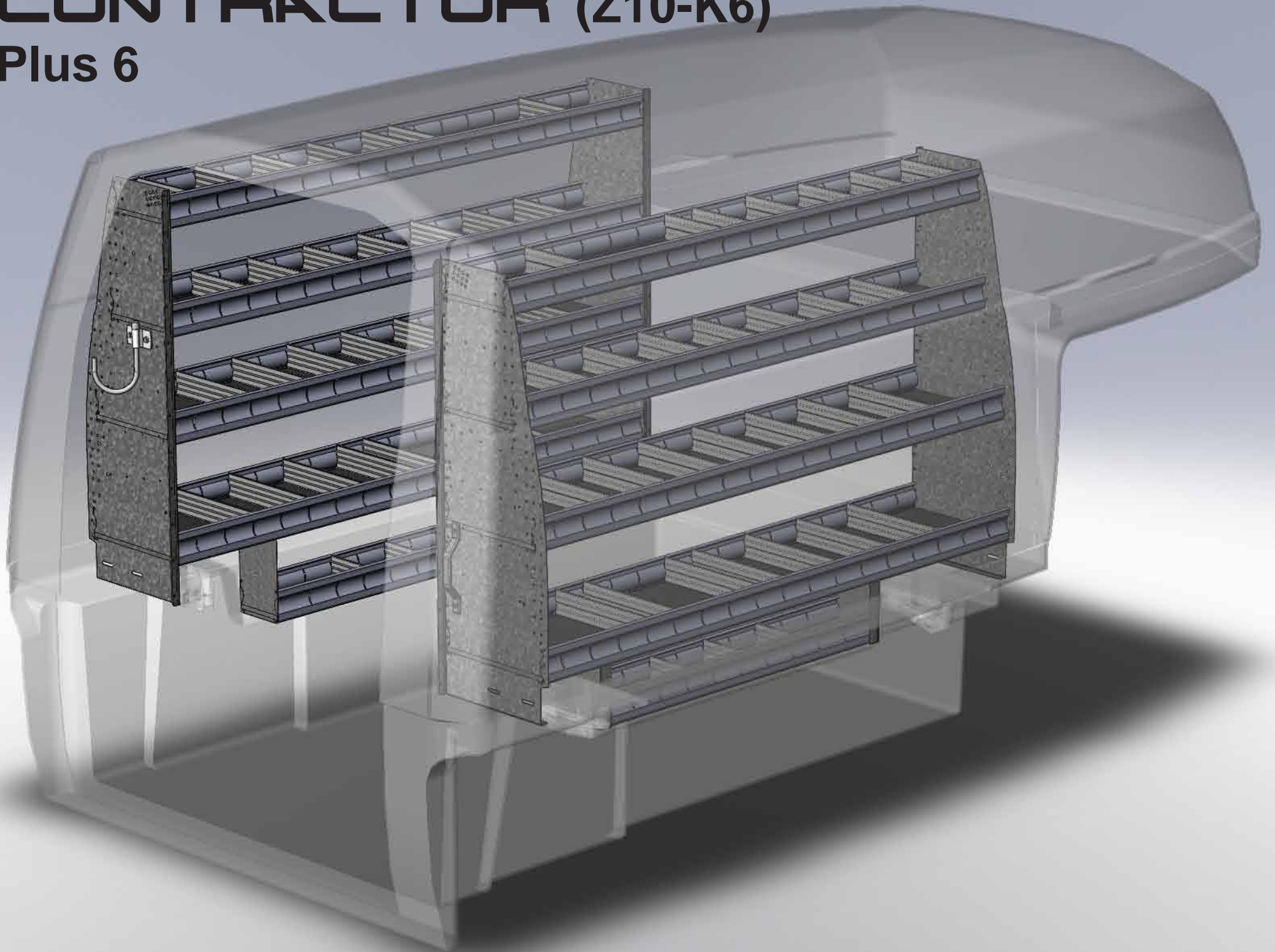
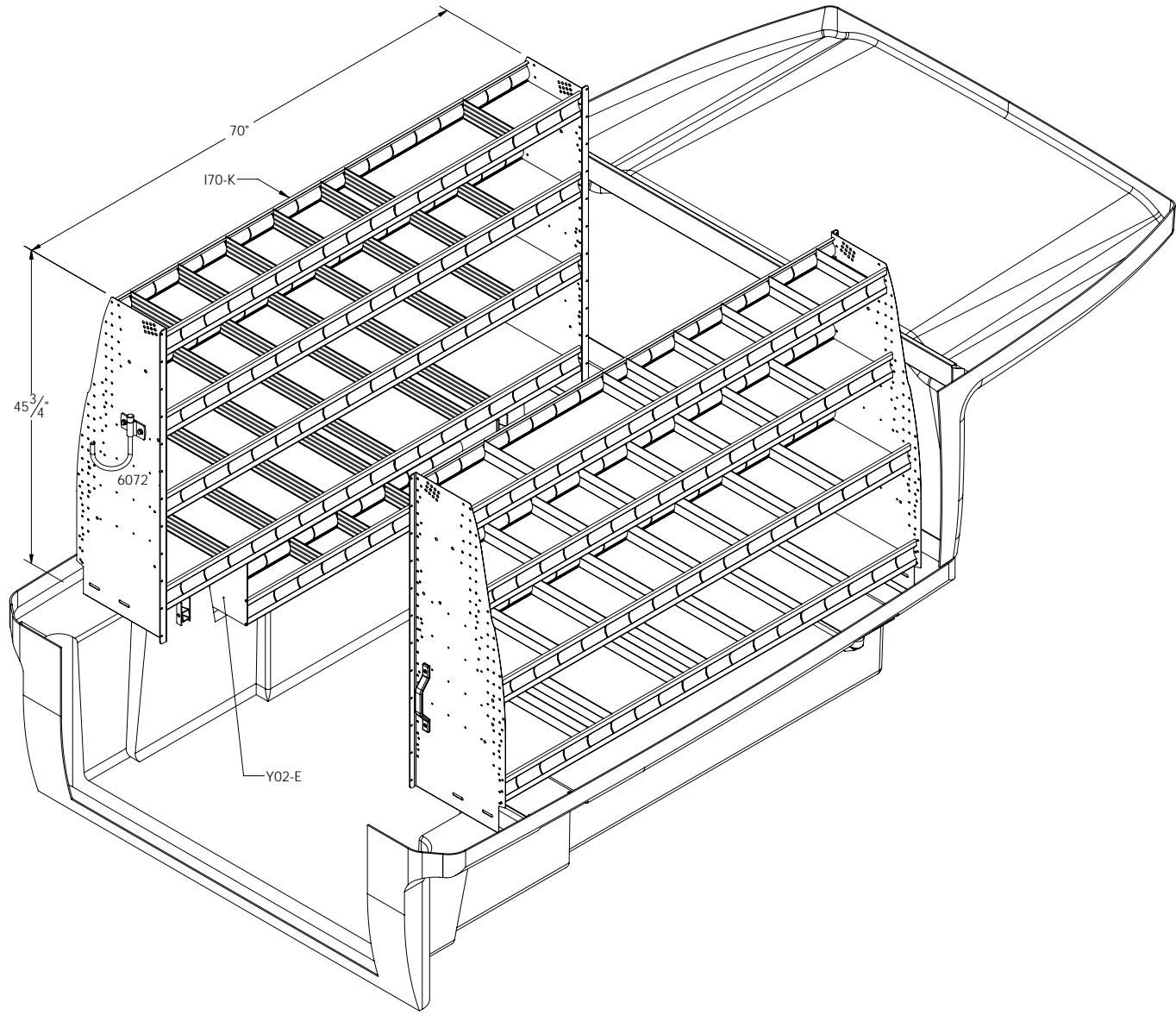

TABLE DE NOMENCLATURE / BOM TABLE		
No	DESCRIPTION	QTE/QTY
170-K	CONTOURED SHELF UNIT, 4 DIVIDED SHELVES - 70"W X 45-3/4"H	2
Y02-E	HALF SHELF - 6"D X 42"W	2
6072	SWIVEL HOOK	1
6093	PLASTIC GRAB HANDLE 9-1/2"	1



SPACEKAP PLUS 6'

**RANGER DESIGN**  
**SPACEKAP**

PROPRIETARY AND CONFIDENTIAL  
 THE INFORMATION CONTAINED IN THIS DRAWING IS THE SOLE  
 PROPERTY OF RANGER DESIGN INC. ANY REPRODUCTION IN PART  
 OR AS A WHOLE WITHOUT THE WRITTEN PERMISSION OF  
 RANGER DESIGN INC IS PROHIBITED.

TITLE:  
 ENSEMBLE POUR CONTRACTEURS  
 CONTRACTORS PACKAGE

SIZE <b>C</b>	DWG. NO. Z10-K6	REV 0
------------------	--------------------	----------

2010-04-30 SCALE: 1:10 SHEET 1 OF 2

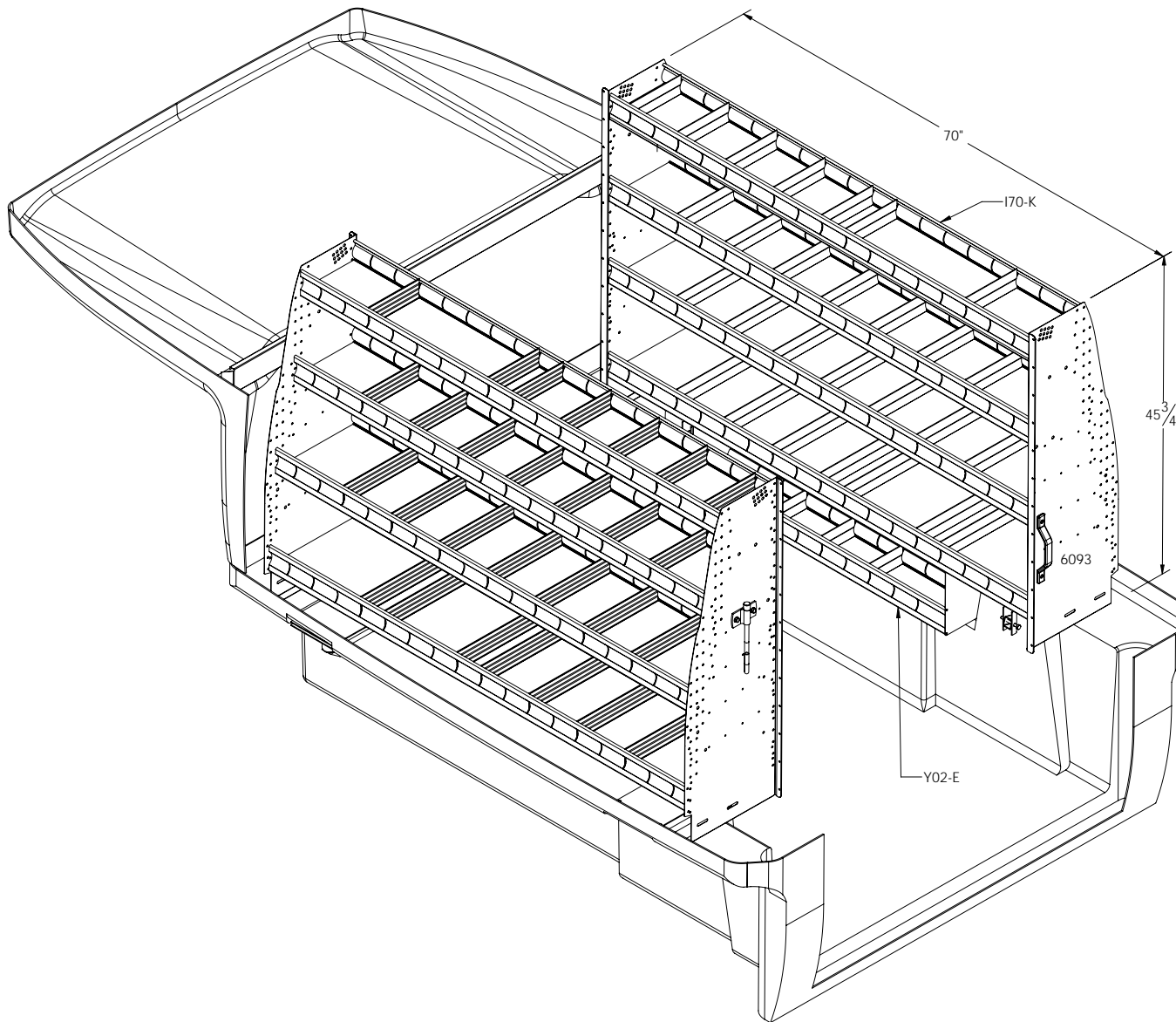

PROPRIETARY AND CONFIDENTIAL  
 THE INFORMATION CONTAINED IN THIS DRAWING IS THE SOLE  
 PROPERTY OF RANGER DESIGN INC. ANY REPRODUCTION IN PART  
 OR AS A WHOLE WITHOUT THE WRITTEN PERMISSION OF  
 RANGER DESIGN INC IS PROHIBITED.

TITLE:  
 ENSEMBLE POUR CONTRACTEURS  
 CONTRACTORS PACKAGE

SIZE <b>C</b>	DWG. NO. Z10-K6	REV 0
2010-04-30	SCALE: 1:10	SHEET 2 OF 2

# PLUMBER / ELECTRICIAN (Z15-K6) Plus 6

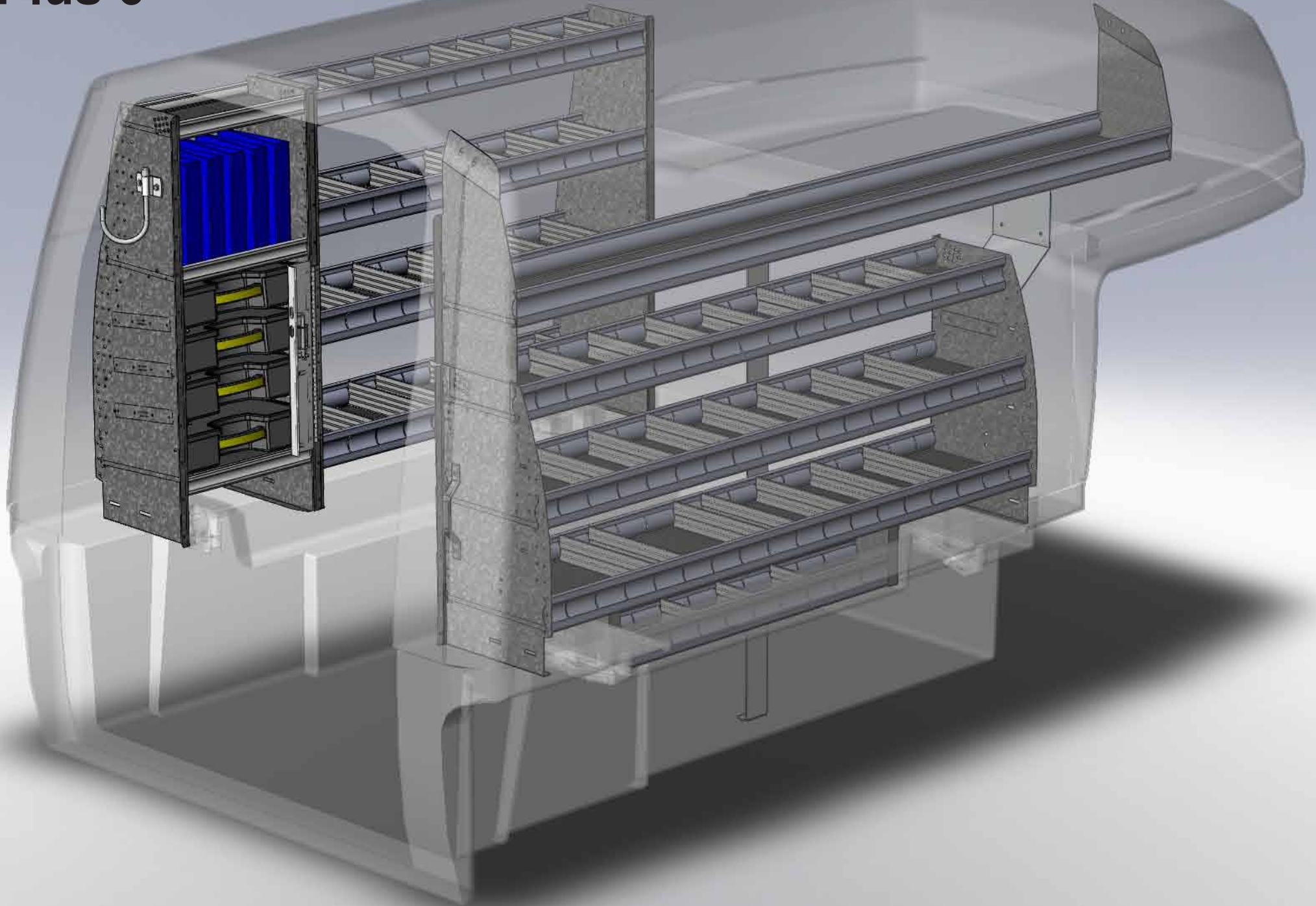
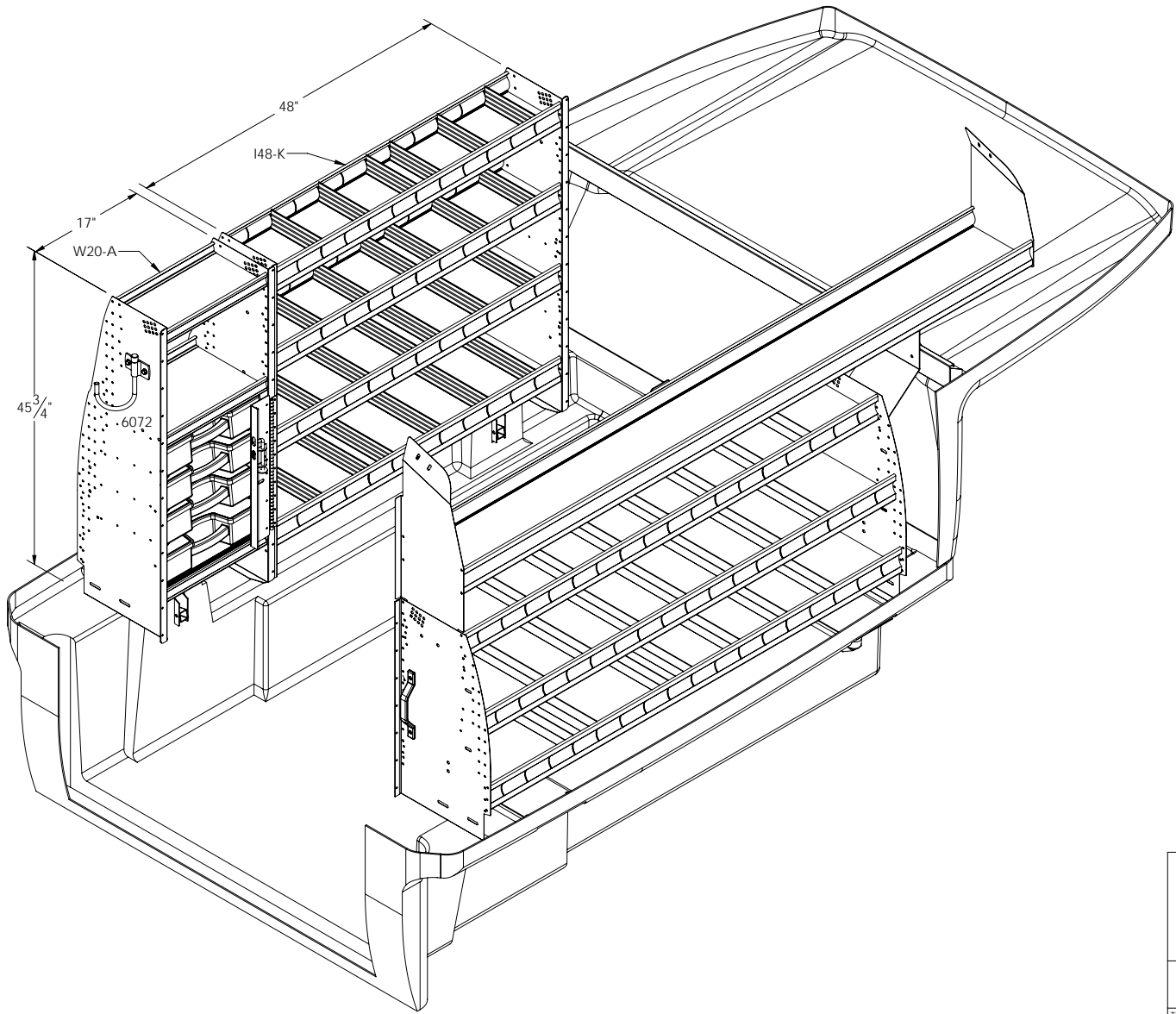

TABLE DE NOMENCLATURE / BOM TABLE		
No	DESCRIPTION	QTE/QTY
I48-K	CONTOURED SHELF UNIT, 4 DIVIDED SHELVES - 48"W X 45-3/4"H	1
W20-A	PARTSKEEPER CABINET W 4 CASE AND 2 SHELVES - 17"W X 45-3/4"H	1
6072	SWIVEL HOOK	1
I70-L	CONTOURED SHELF UNIT, 3 DIVIDED SHELVES - 70"W X 28-1/2"H	1
Y03-K	TOP SHELF - 9"D X 96"W	1
Y02-E	HALF SHELF - 6"D X 42"W	1
6093	PLASTIC GRAB HANDLE 9-1/2"	1



SPACEKAP PLUS 6'

**RANGER DESIGN**  
**SPACEKAP**

PROPRIETARY AND CONFIDENTIAL  
 THE INFORMATION CONTAINED IN THIS DRAWING IS THE SOLE PROPERTY OF RANGER DESIGN INC. ANY REPRODUCTION IN PART OR AS A WHOLE WITHOUT THE WRITTEN PERMISSION OF RANGER DESIGN INC IS PROHIBITED.

TITLE:  
 ENSEMBLE POUR PLOMBIERS  
 PLUMBERS PACKAGE

SIZE <b>C</b>	DWG. NO. Z15-K6	REV 0
2010-05-01	SCALE: 1:10	SHEET 1 OF 2

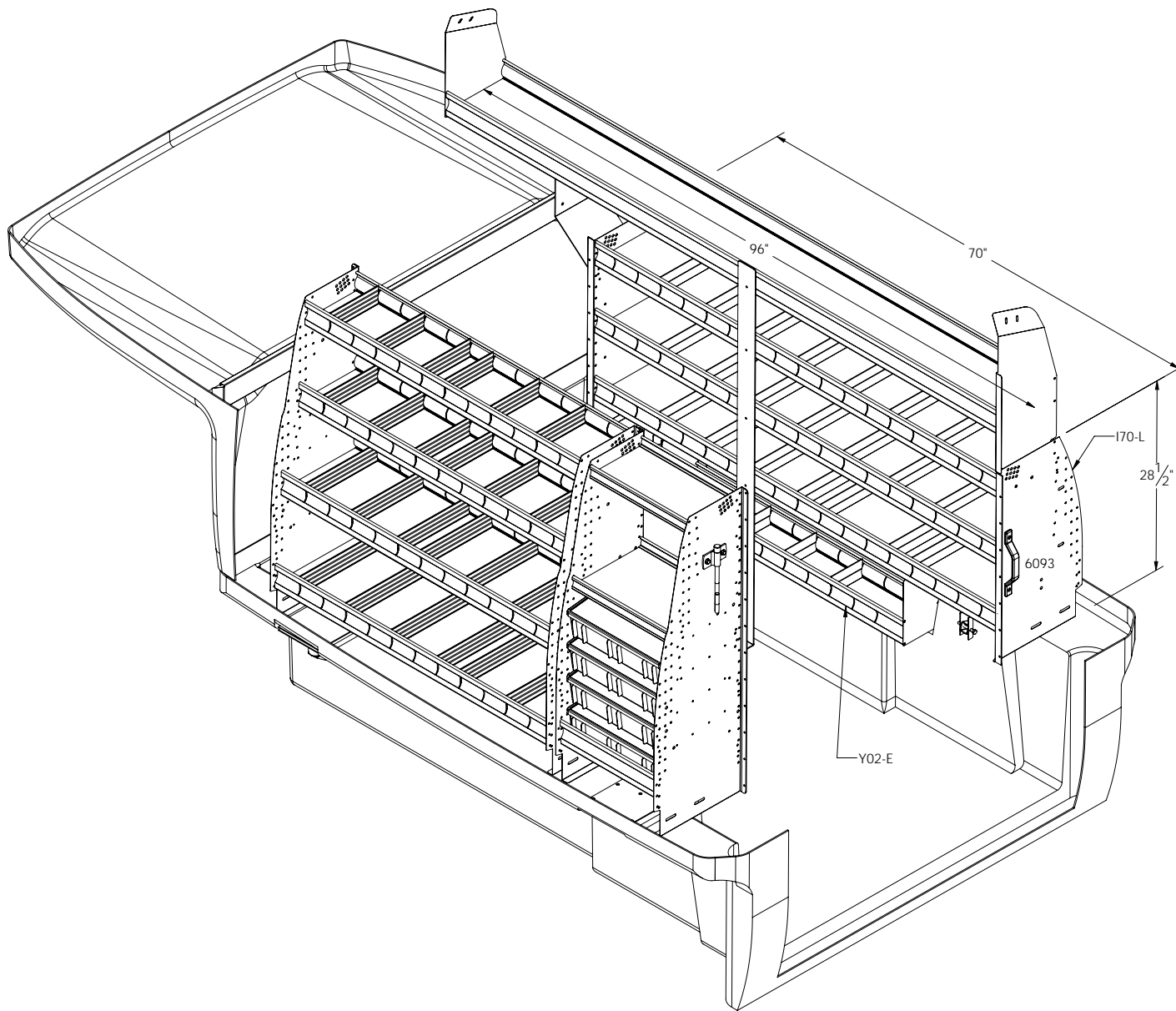

PROPRIETARY AND CONFIDENTIAL  
 THE INFORMATION CONTAINED IN THIS DRAWING IS THE SOLE  
 PROPERTY OF RANGER DESIGN INC. ANY REPRODUCTION IN PART  
 OR AS A WHOLE WITHOUT THE WRITTEN PERMISSION OF  
 RANGER DESIGN INC IS PROHIBITED.

TITLE:  
 ENSEMBLE POUR PLOMBIERS  
 PLUMBERS PACKAGE

SIZE <b>C</b>	DWG. NO. Z15-K6	REV 0
2010-05-01	SCALE: 1:10	SHEET 2 OF 2

# SERVICE (Z16-K6 )

Plus 6

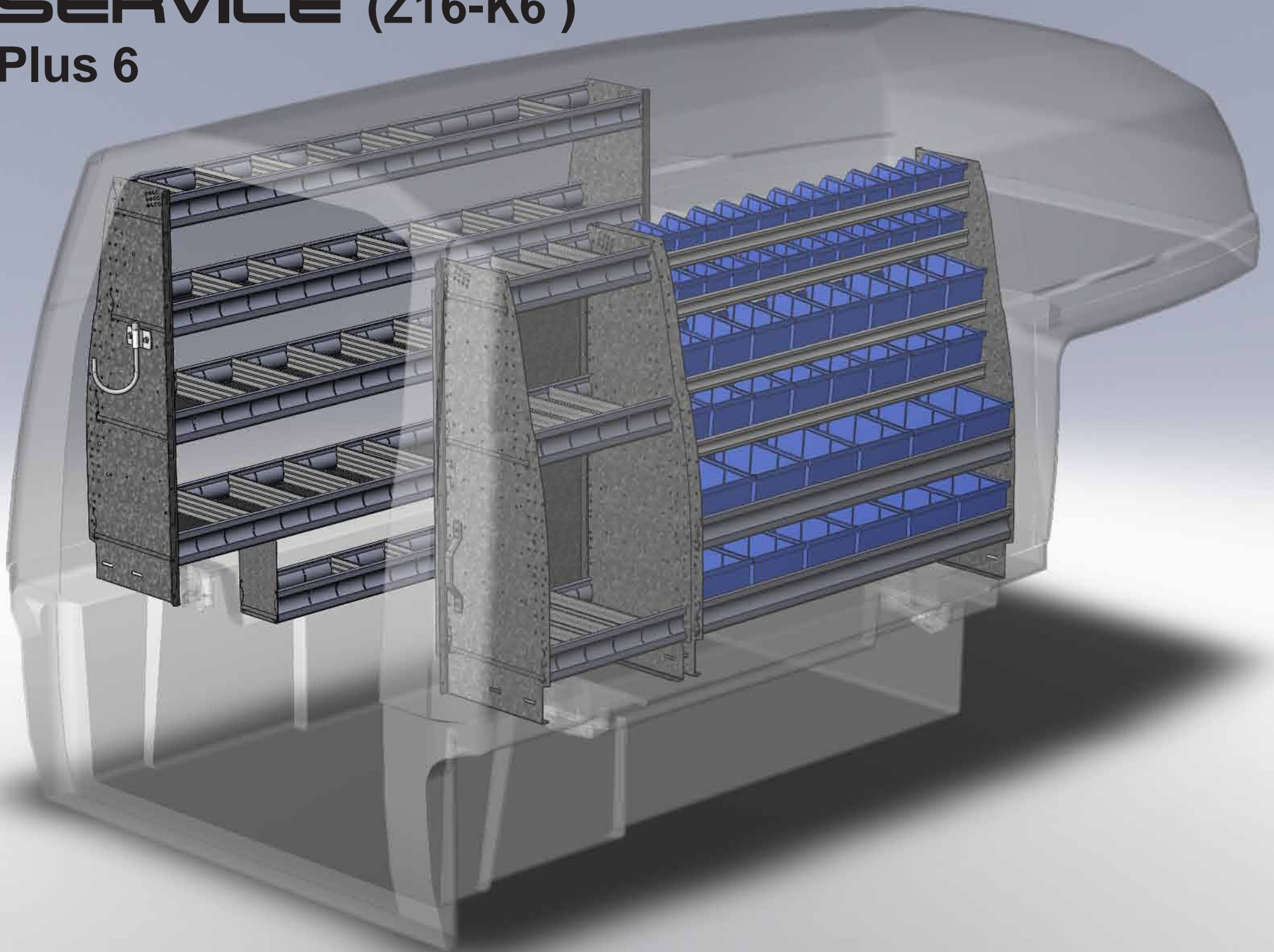
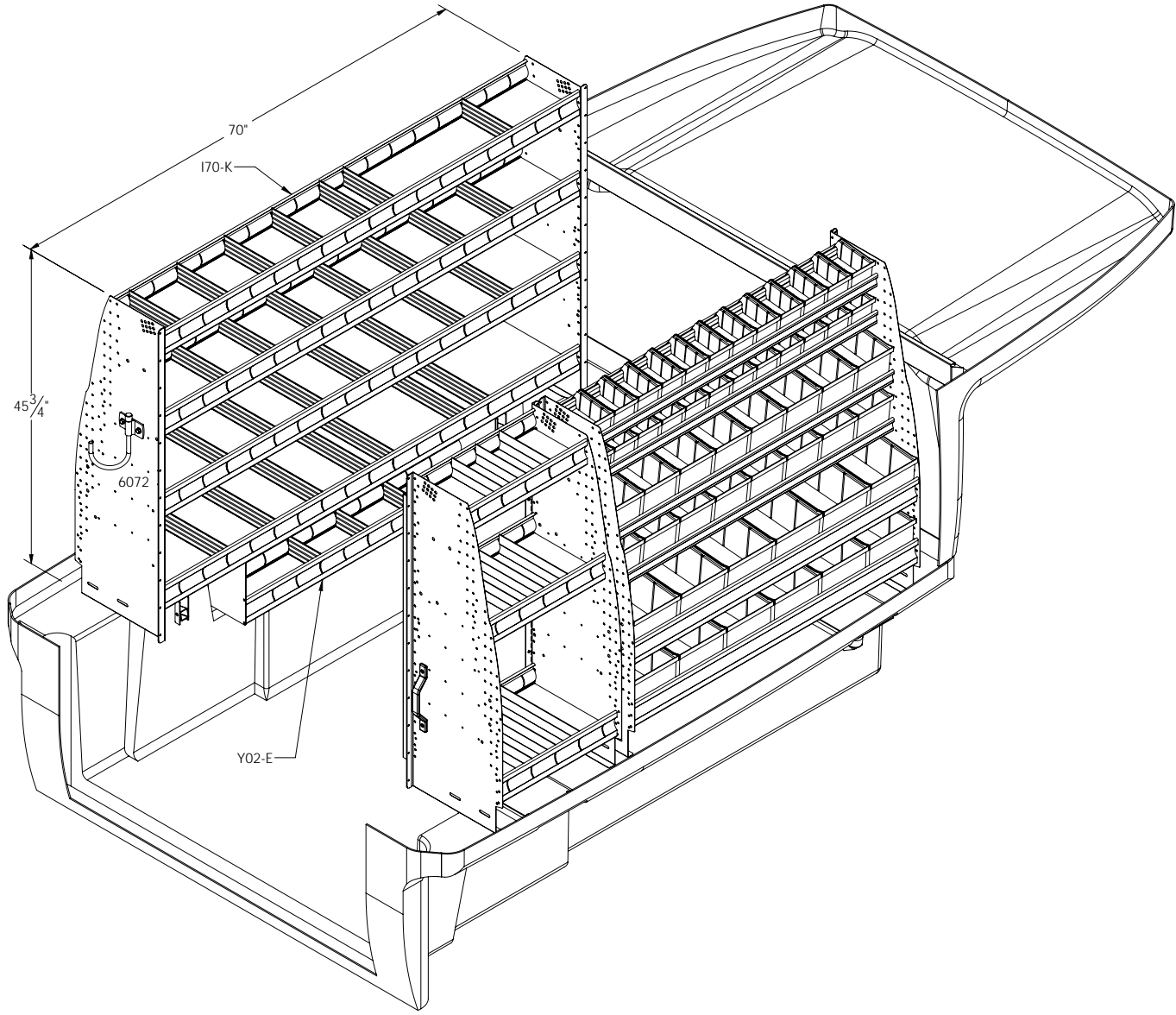

TABLE DE NOMENCLATURE / BOM TABLE		
No	DESCRIPTION	QTE/QTY
I70-K	CONTOURED SHELF UNIT, 4 DIVIDED SHELVES - 70"W X 45-3/4"H	1
Y02-E	HALF SHELF - 6"D X 42"W	1
M48-K	CONTOURED BIN UNIT, 6 SHELVES W/BINS, 48"W X 45-1/2"H	1
S20-K	LOCKER, THREE DIVIDED SHELVES, 20"W X 45-3/4"H	1
6072	SWIVEL HOOK	1
6093	PLASTIC GRAB HANDLE 9-1/2"	1



SPACEKAP PLUS 6'

**RANGER DESIGN**  
**SPACEKAP**

PROPRIETARY AND CONFIDENTIAL  
 THE INFORMATION CONTAINED IN THIS DRAWING IS THE SOLE  
 PROPERTY OF RANGER DESIGN INC. ANY REPRODUCTION IN PART  
 OR AS A WHOLE WITHOUT THE WRITTEN PERMISSION OF  
 RANGER DESIGN INC IS PROHIBITED.

TITLE: ENSEMBLE POUR SERVICE  
 SERVICE PACKAGE

SIZE <b>C</b>	DWG. NO. Z16-K6	REV 0
2010-04-30	SCALE: 1:10	SHEET 1 OF 2



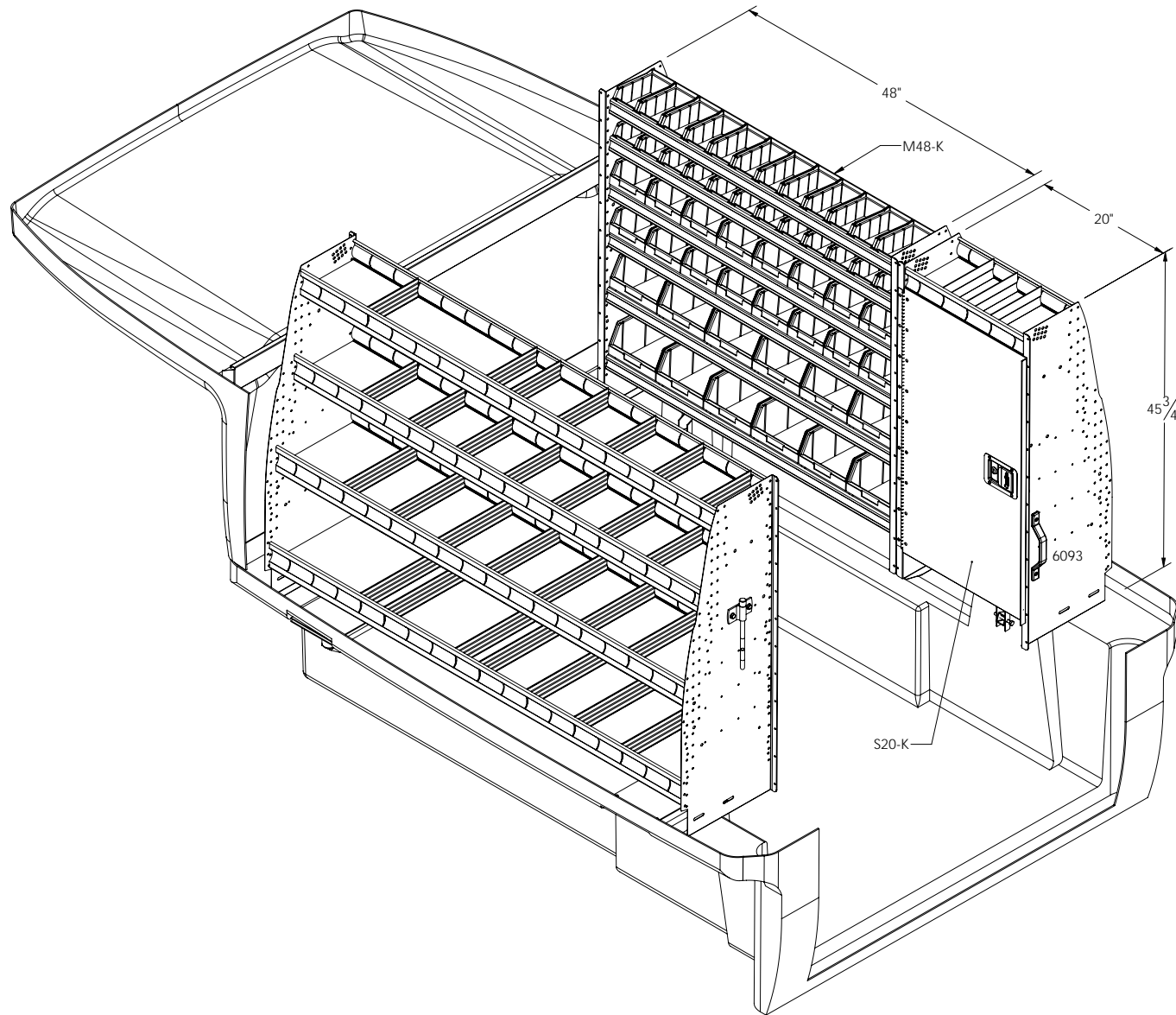

PROPRIETARY AND CONFIDENTIAL  
 THE INFORMATION CONTAINED IN THIS DRAWING IS THE SOLE  
 PROPERTY OF RANGER DESIGN INC. ANY REPRODUCTION IN PART  
 OR AS A WHOLE WITHOUT THE WRITTEN PERMISSION OF  
 RANGER DESIGN INC IS PROHIBITED.

TITLE:  
 ENSEMBLE POUR SERVICE  
 SERVICE PACKAGE

SIZE <b>C</b>	DWG. NO. Z16-K6	REV 0
2010-04-30	SCALE: 1:10	SHEET 2 OF 2

# WORK STATION (Z17-K6)

Plus 6

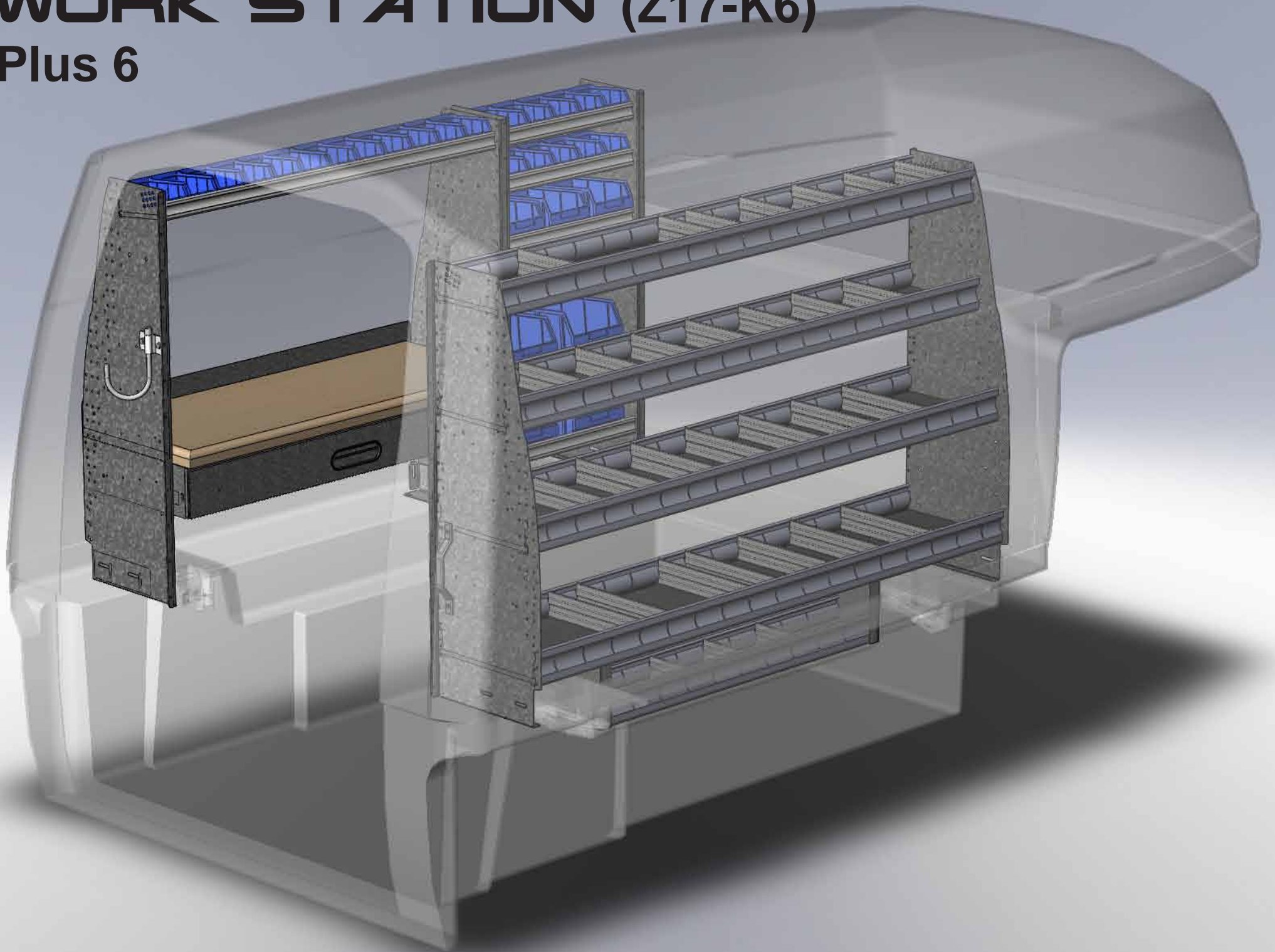
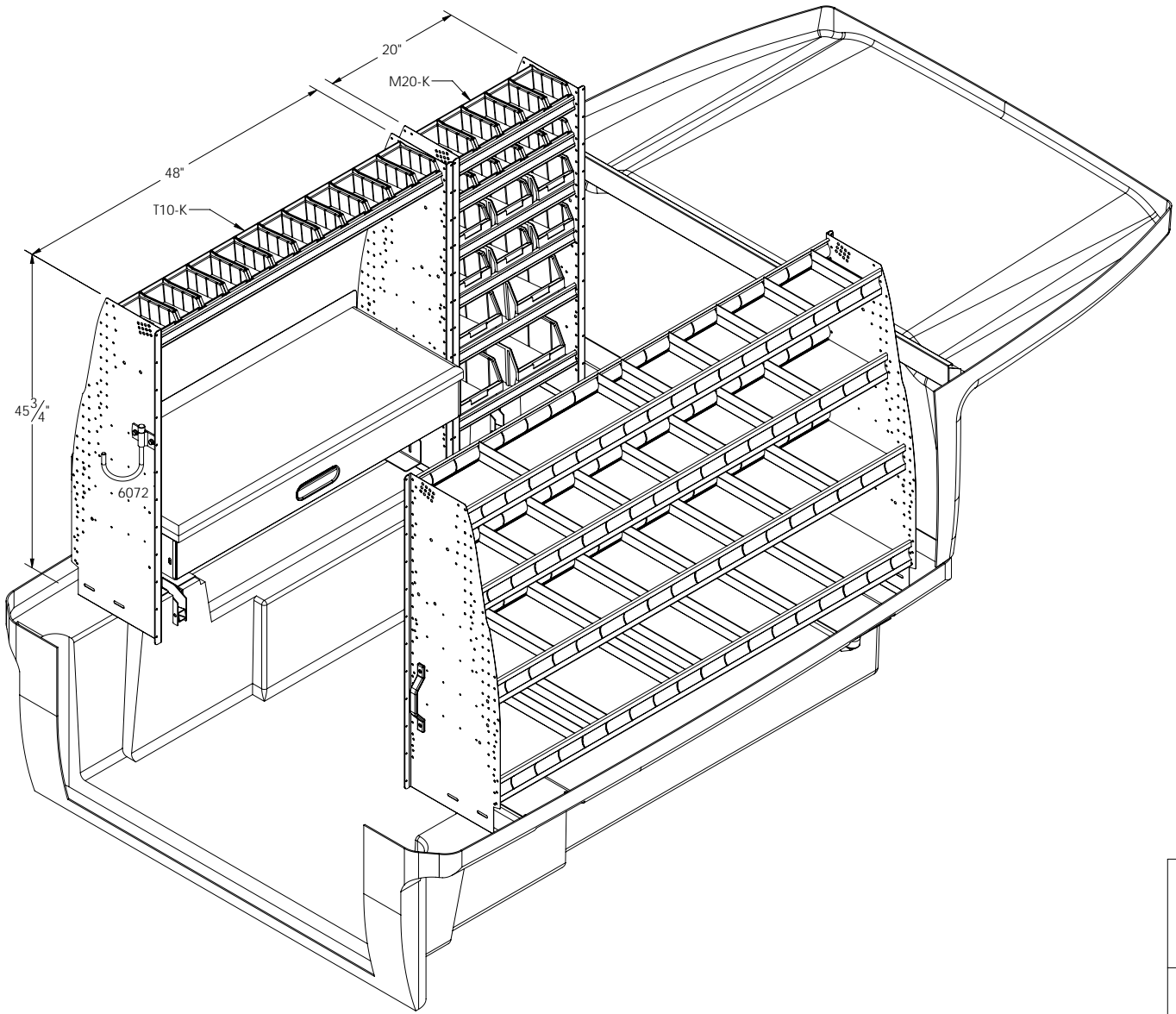

TABLE DE NOMENCLATURE / BOM TABLE		
No	DESCRIPTION	QTE/QTY
M20-K	CONTOURED BIN UNIT, 6 SHELVES W/BINS, 20"W X 45-1/2"H	1
T10-K	WORKBENCH WITH PULL OUT DRAWER, 18"D X 48"W	1
I70-K	CONTOURED SHELF UNIT, 4 DIVIDED SHELVES - 70"W X 45-3/4"H	1
6072	SWIVEL HOOK	1
6093	PLASTIC GRAB HANDLE 9-1/2"	1
Y02-E	HALF SHELF - 6"D X 42"W	1



SPACEKAP PLUS 6'

**RANGER DESIGN**  
**SPACEKAP**

PROPRIETARY AND CONFIDENTIAL  
 THE INFORMATION CONTAINED IN THIS DRAWING IS THE SOLE PROPERTY OF RANGER DESIGN INC. ANY REPRODUCTION IN PART OR AS A WHOLE WITHOUT THE WRITTEN PERMISSION OF RANGER DESIGN INC IS PROHIBITED.

TITLE: ENSEMBLE ATELIER  
 WORKSTATION PACKAGE

SIZE <b>C</b>	DWG. NO. Z17-K6	REV 0
2010-05-01	SCALE: 1:10	SHEET 1 OF 2

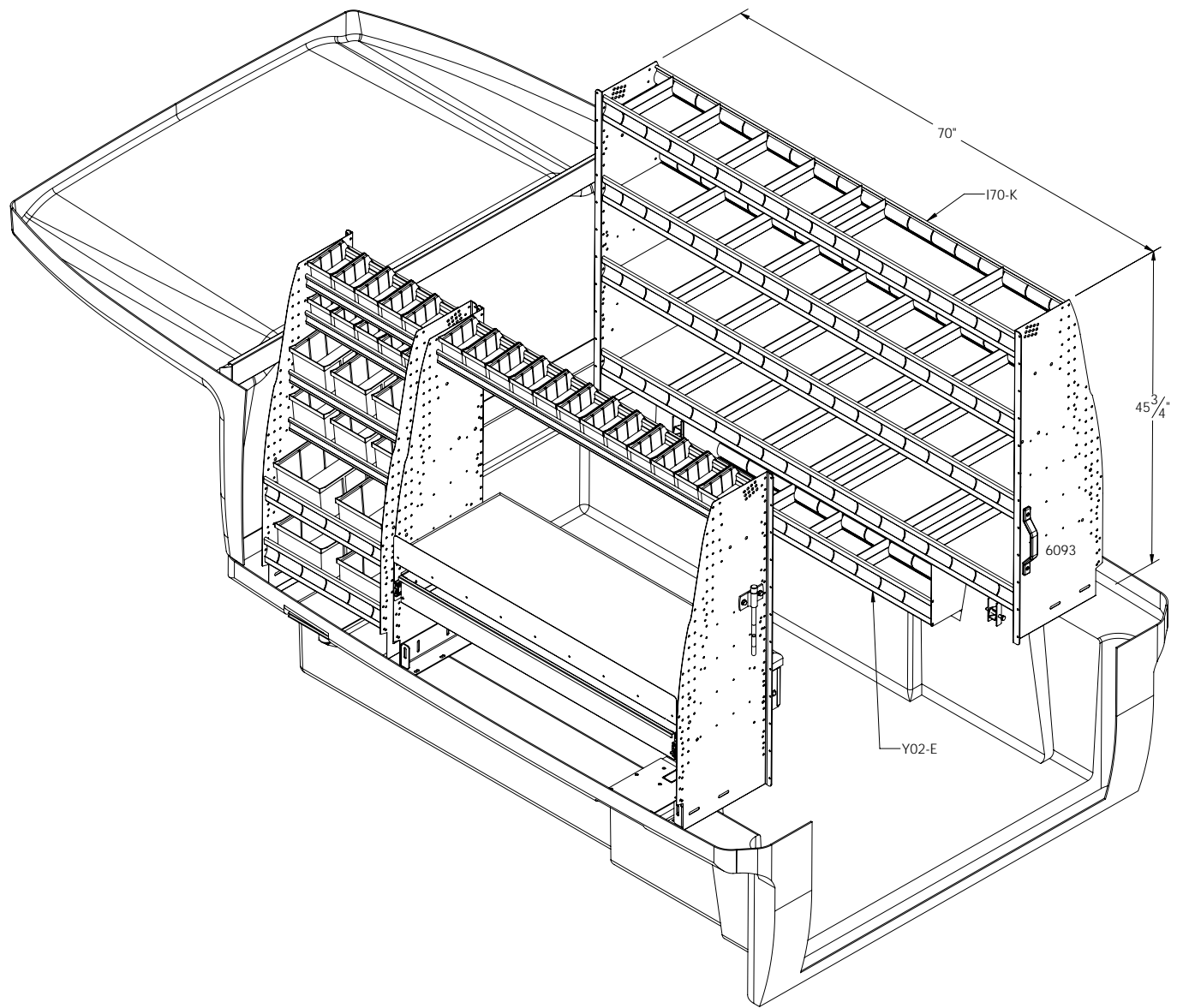

PROPRIETARY AND CONFIDENTIAL  
THE INFORMATION CONTAINED IN THIS DRAWING IS THE SOLE  
PROPERTY OF RANGER DESIGN INC. ANY REPRODUCTION IN PART  
OR AS A WHOLE WITHOUT THE WRITTEN PERMISSION OF  
RANGER DESIGN INC IS PROHIBITED.

TITLE: ENSEMBLE ATELIER  
WORKSTATION PACKAGE

SIZE <b>C</b>	DWG. NO. Z17-K6	REV 0
2010-05-01	SCALE: 1:10	SHEET 2 OF 2

# CONTRACTOR (Z10-K8)

Plus 8

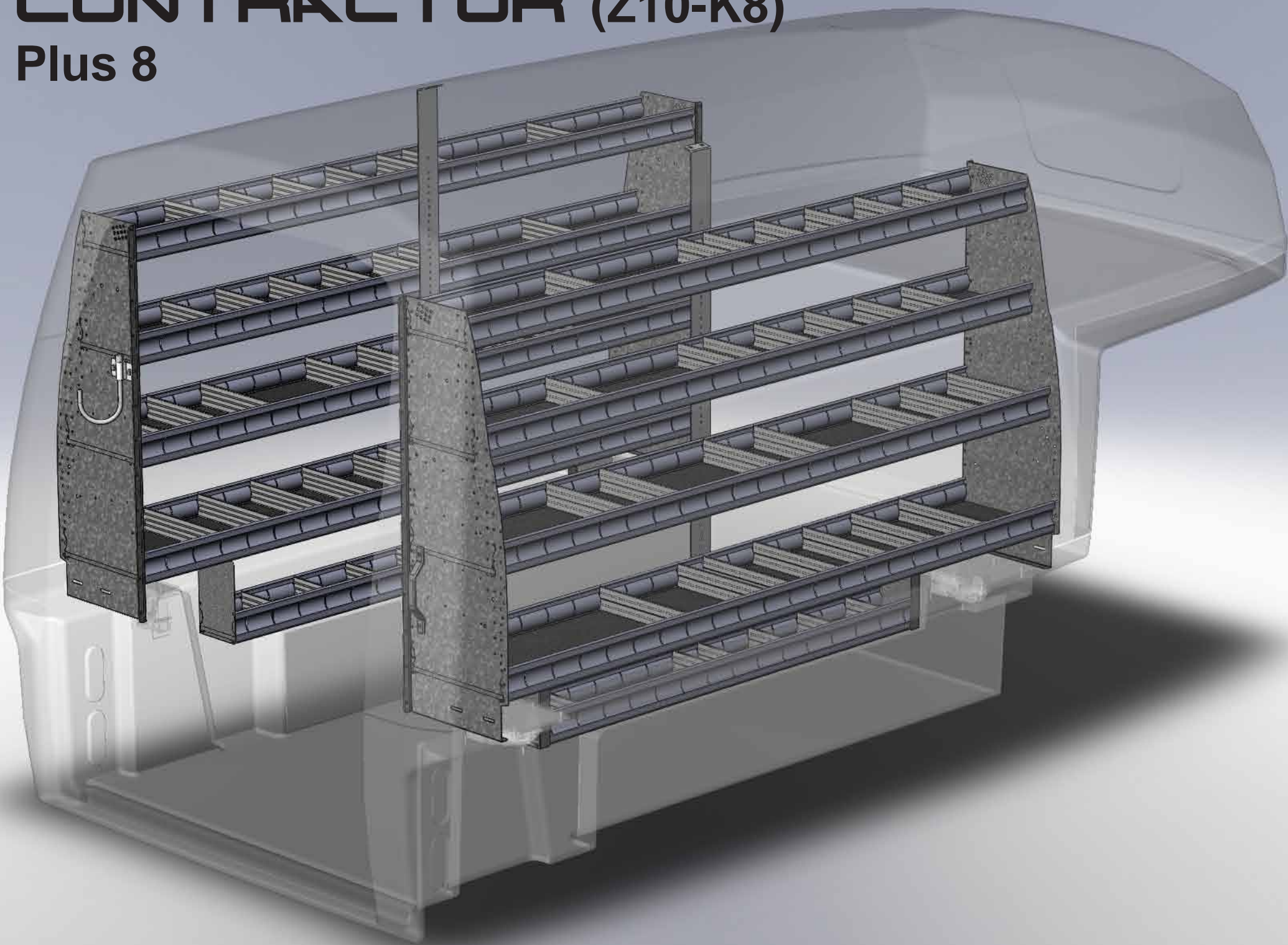
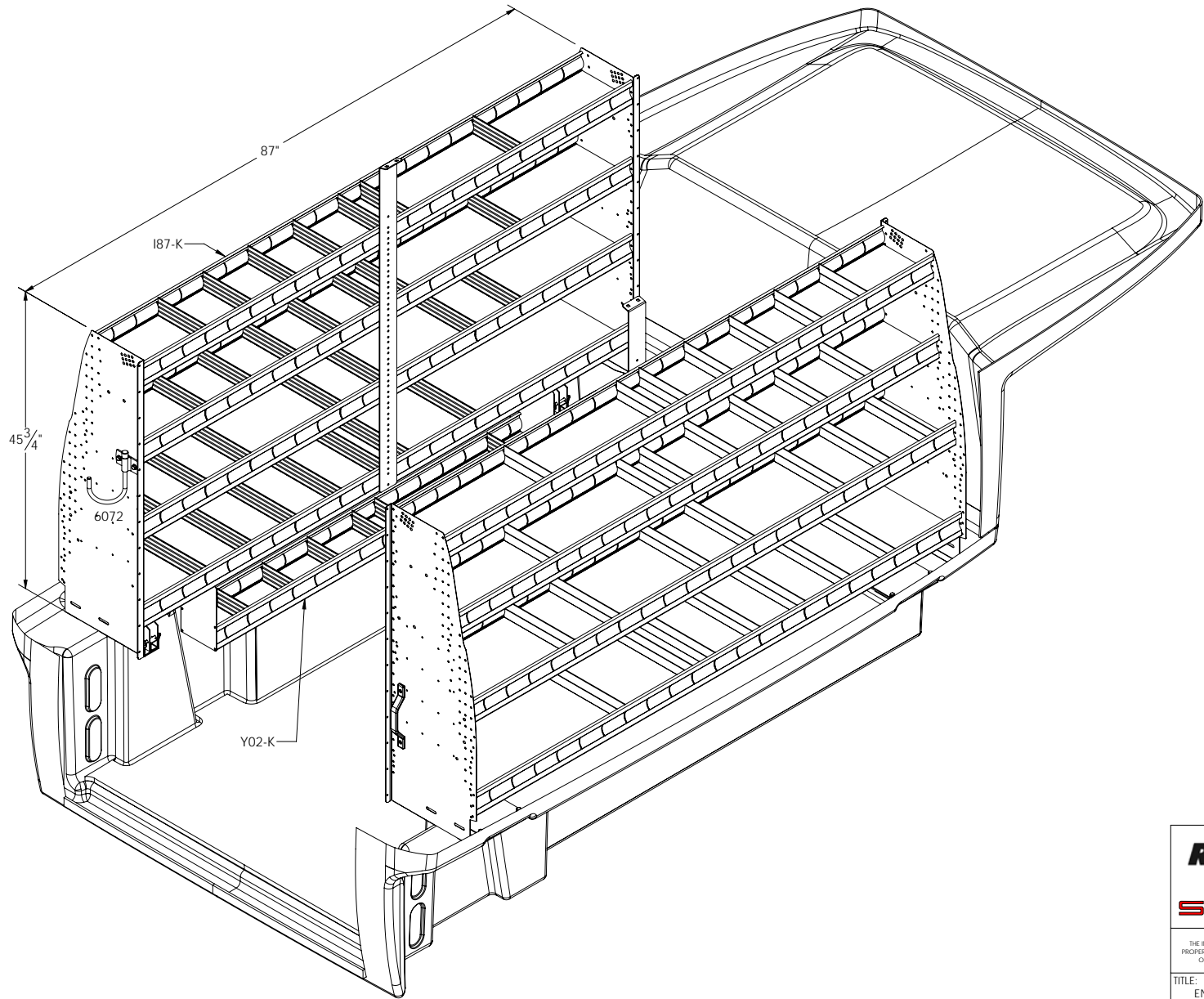

TABLE DE NOMENCLATURE / BOM TABLE		
No	DESCRIPTION	QTE/QTY
187-K	CONTOURED SHELF UNIT, 4 DIVIDED SHELVES, 87"W X 45-3/4"H	2
Y02-K	HALF SHELF - 6"D X 60"W	2
6072	SWIVEL HOOK	1
6093	PLASTIC GRAB HANDLE 9-1/2"	1



SPACEKAP PLUS 8'

**RANGER DESIGN**  
**SPACEKAP**

PROPRIETARY AND CONFIDENTIAL  
 THE INFORMATION CONTAINED IN THIS DRAWING IS THE SOLE PROPERTY OF RANGER DESIGN INC. ANY REPRODUCTION IN PART OR AS A WHOLE WITHOUT THE WRITTEN PERMISSION OF RANGER DESIGN INC IS PROHIBITED.

TITLE:  
 ENSEMBLE POUR CONTRACTEURS  
 CONTRACTORS PACKAGE

SIZE <b>C</b>	DWG. NO. Z10-K8	REV 0
2010-03-04	SCALE: 1:10	SHEET 1 OF 2

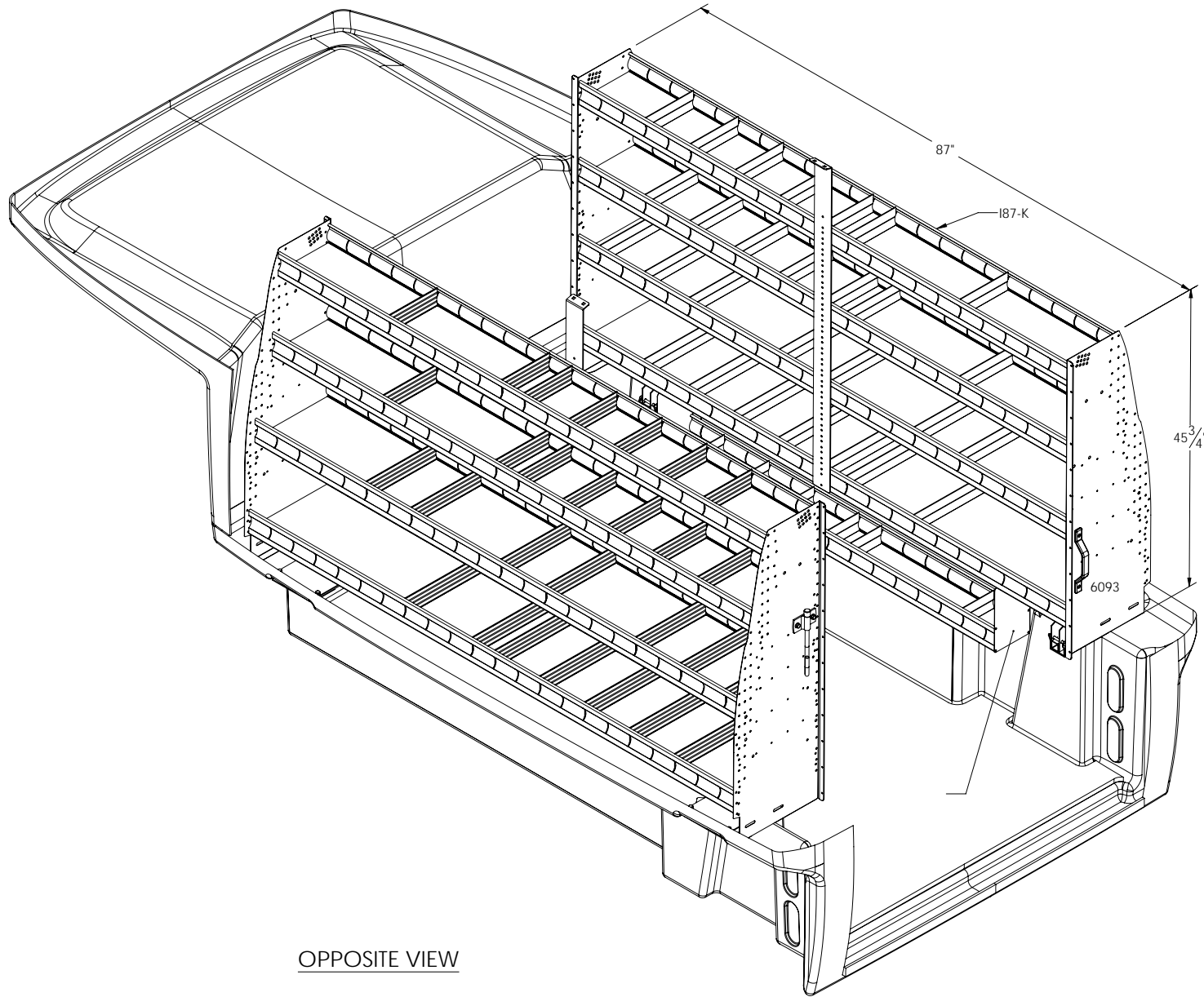

OPPOSITE VIEW



PROPRIETARY AND CONFIDENTIAL  
 THE INFORMATION CONTAINED IN THIS DRAWING IS THE SOLE  
 PROPERTY OF RANGER DESIGN INC. ANY REPRODUCTION IN PART  
 OR AS A WHOLE WITHOUT THE WRITTEN PERMISSION OF  
 RANGER DESIGN INC IS PROHIBITED.

TITLE:  
 ENSEMBLE POUR CONTRACTEURS  
 CONTRACTORS PACKAGE

SIZE <b>C</b>	DWG. NO. Z10-K8	REV 0
2010-03-04	SCALE: 1:10	SHEET 2 OF 2

# PLUMBER / ELECTRICIAN (Z15-K8)

Plus 8

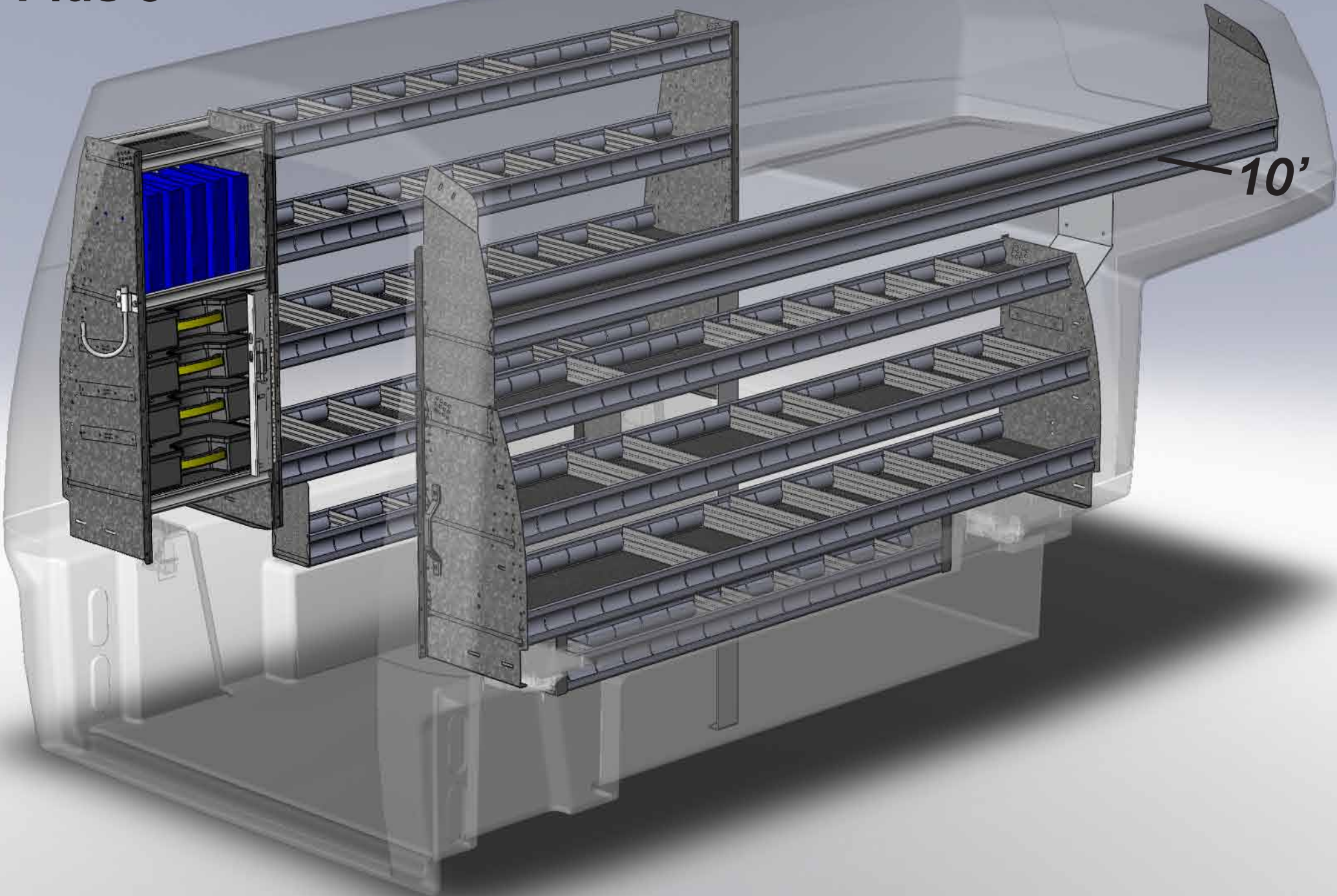

10"



TABLE DE NOMENCLATURE / BOM TABLE		
No	DESCRIPTION	QTE/QTY
I70-K	CONTOURED SHELF UNIT, 4 DIVIDED SHELVES - 70"W X 45-3/4"H	1
W20-A	PARTSKEEPER CABINET W 4 CASE AND 2 SHELVES - 17"W X 45-3/4"H	1
Y01-K	HALF SHELF - 6"D X 48"W	1
6072	SWIVEL HOOK	1
I87-L	CONTOURED SHELF UNIT, 3 DIVIDED SHELVES - 87"W X 28-1/2"H	1
Y04-K	TOP SHELF - 9"D X 120"W	1
Y02-K	HALF SHELF - 6"D X 60"W	1
6093	PLASTIC GRAB HANDLE 9-1/2"	1

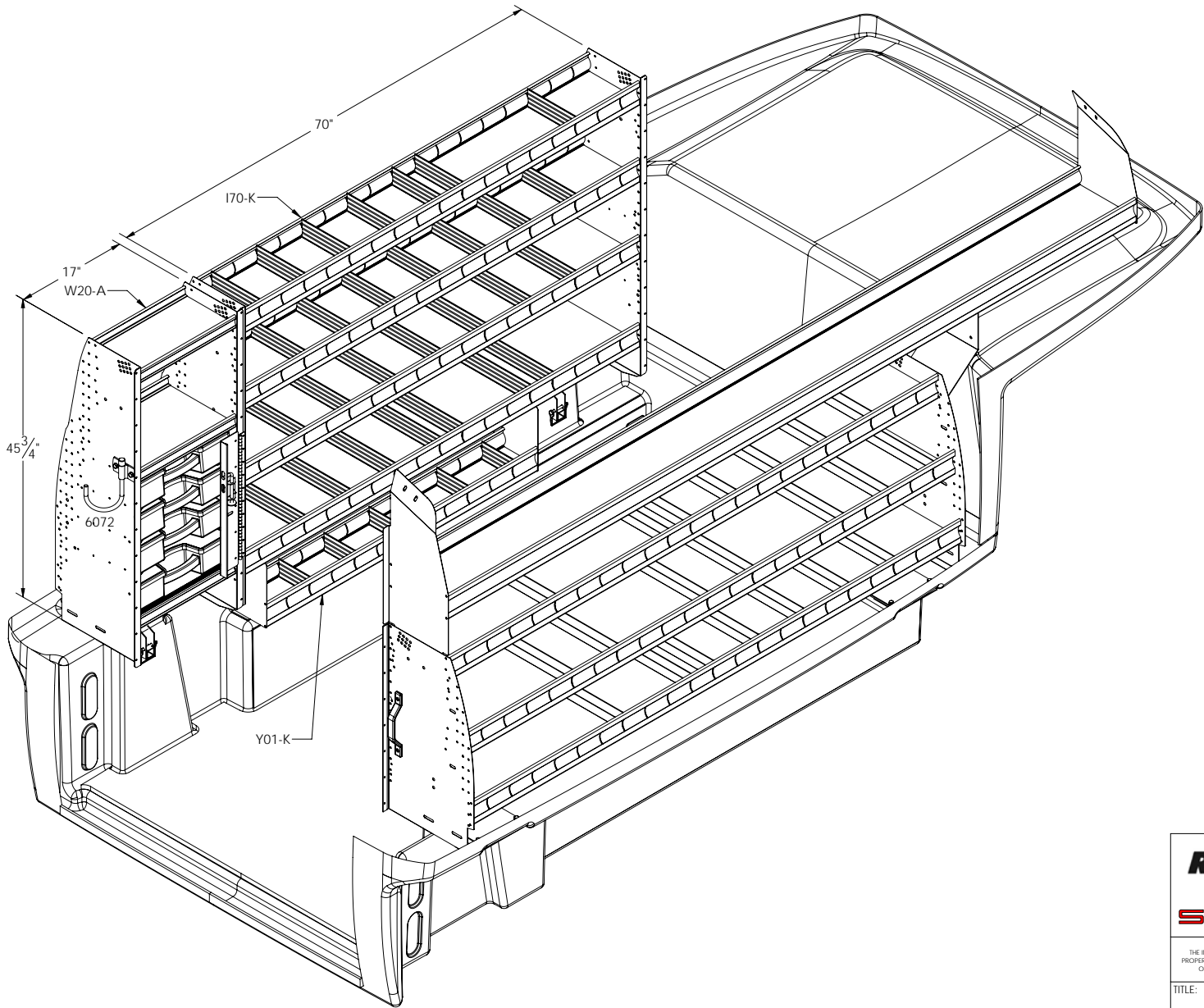

SPACEKAP PLUS 8'

**RANGER DESIGN**  
**SPACEKAP**

PROPRIETARY AND CONFIDENTIAL  
 THE INFORMATION CONTAINED IN THIS DRAWING IS THE SOLE PROPERTY OF RANGER DESIGN INC. ANY REPRODUCTION IN PART OR AS A WHOLE WITHOUT THE WRITTEN PERMISSION OF RANGER DESIGN INC IS PROHIBITED.

TITLE:  
 ENSEMBLE POUR PLOMBIERS  
 PLUMBERS PACKAGE

SIZE <b>C</b>	DWG. NO. Z15-K8	REV 0
2010-03-04	SCALE: 1:10	SHEET 1 OF 2

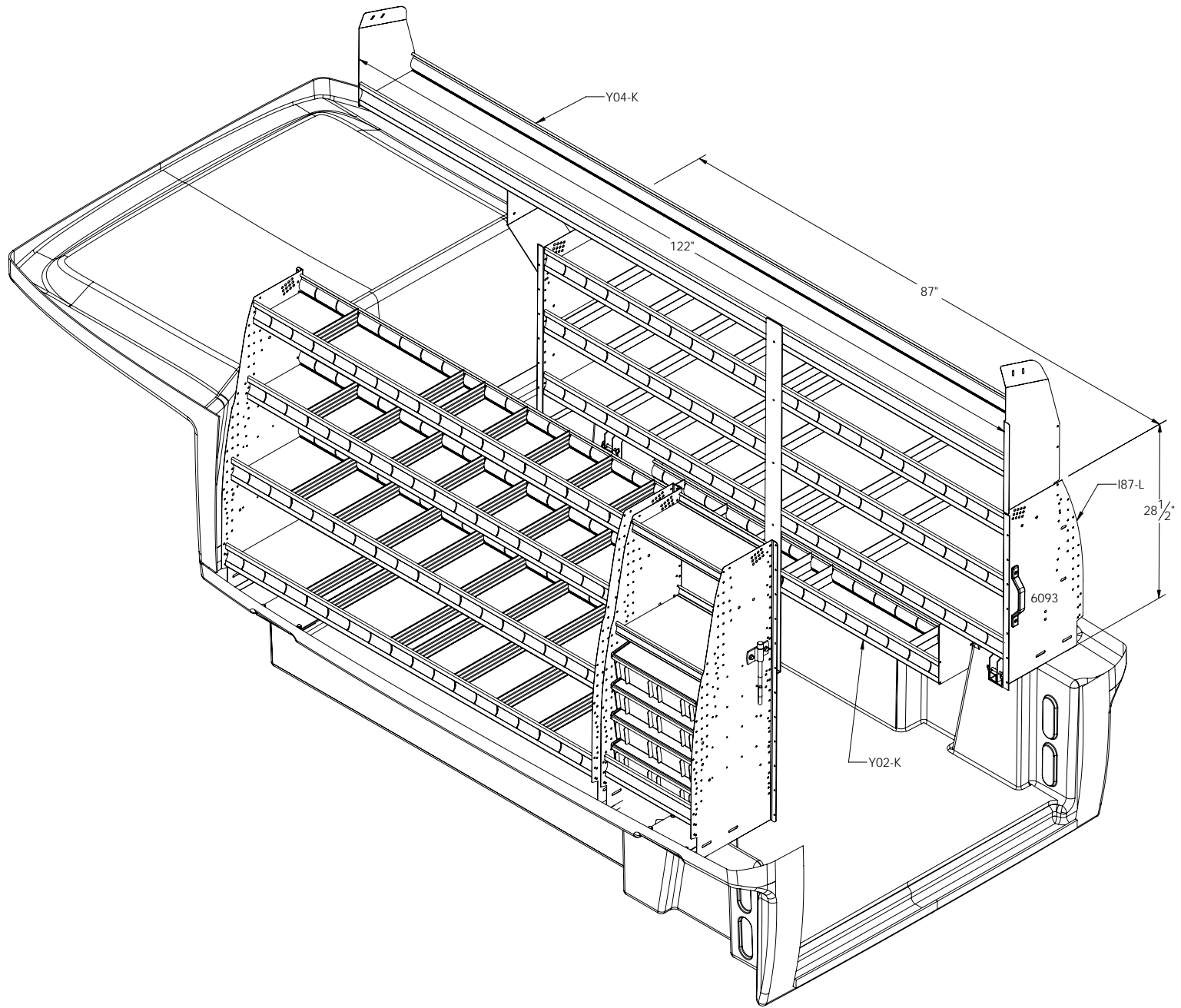

**RANGER**  
DESIGN

**SPACEKAP**

PROPRIETARY AND CONFIDENTIAL  
THE INFORMATION CONTAINED IN THIS DRAWING IS THE SOLE  
PROPERTY OF RANGER DESIGN INC. ANY REPRODUCTION IN PART  
OR AS A WHOLE WITHOUT THE WRITTEN PERMISSION OF  
RANGER DESIGN INC IS PROHIBITED.

TITLE:  
ENSEMBLE POUR PLOMBIERS  
PLUMBERS PACKAGE

SIZE <b>C</b>	DWG. NO. Z15-K8	REV 0
2010-03-04	SCALE: 1:10	SHEET 2 OF 2

# SERVICE (Z16-K8)

Plus 8

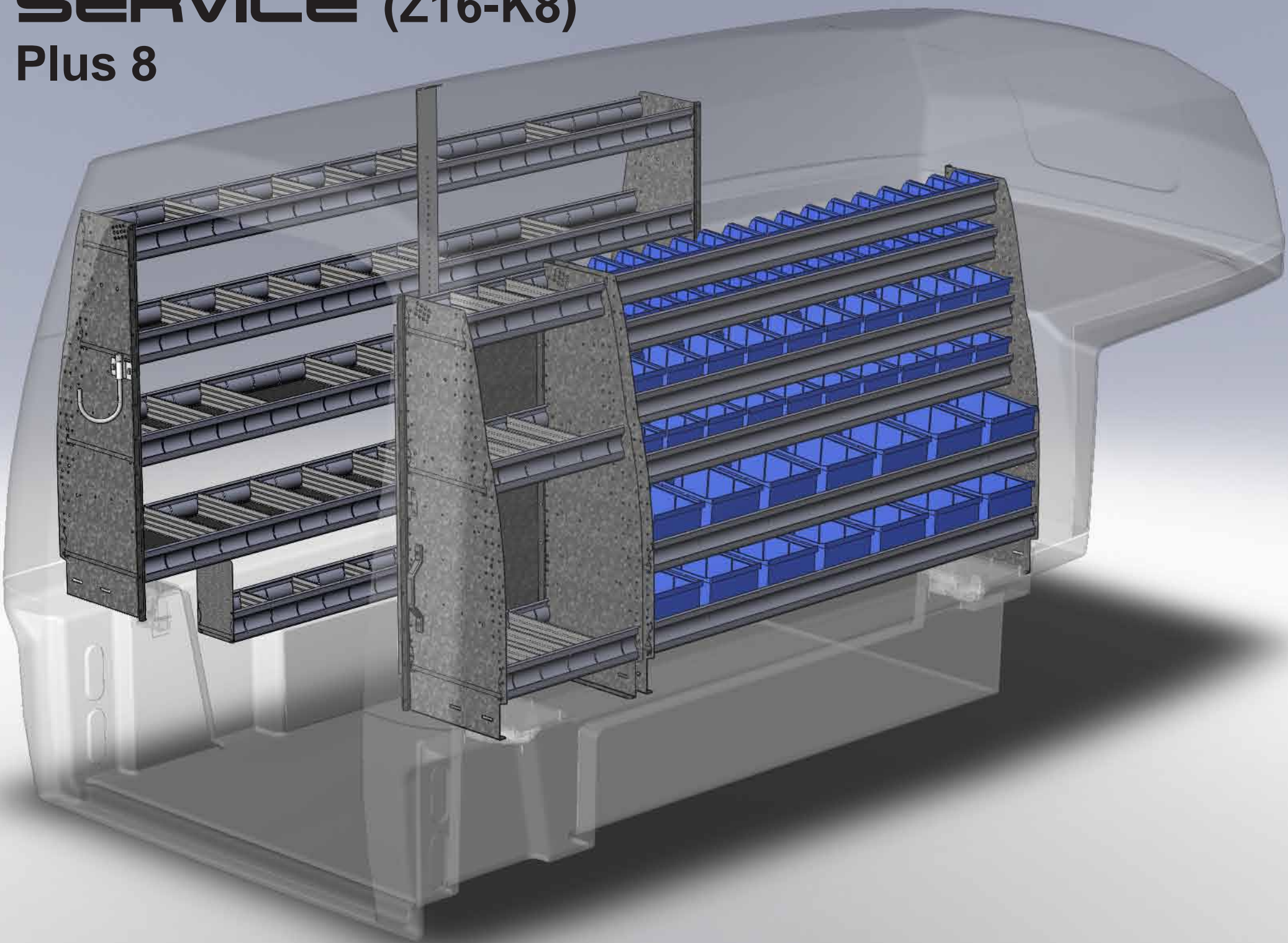
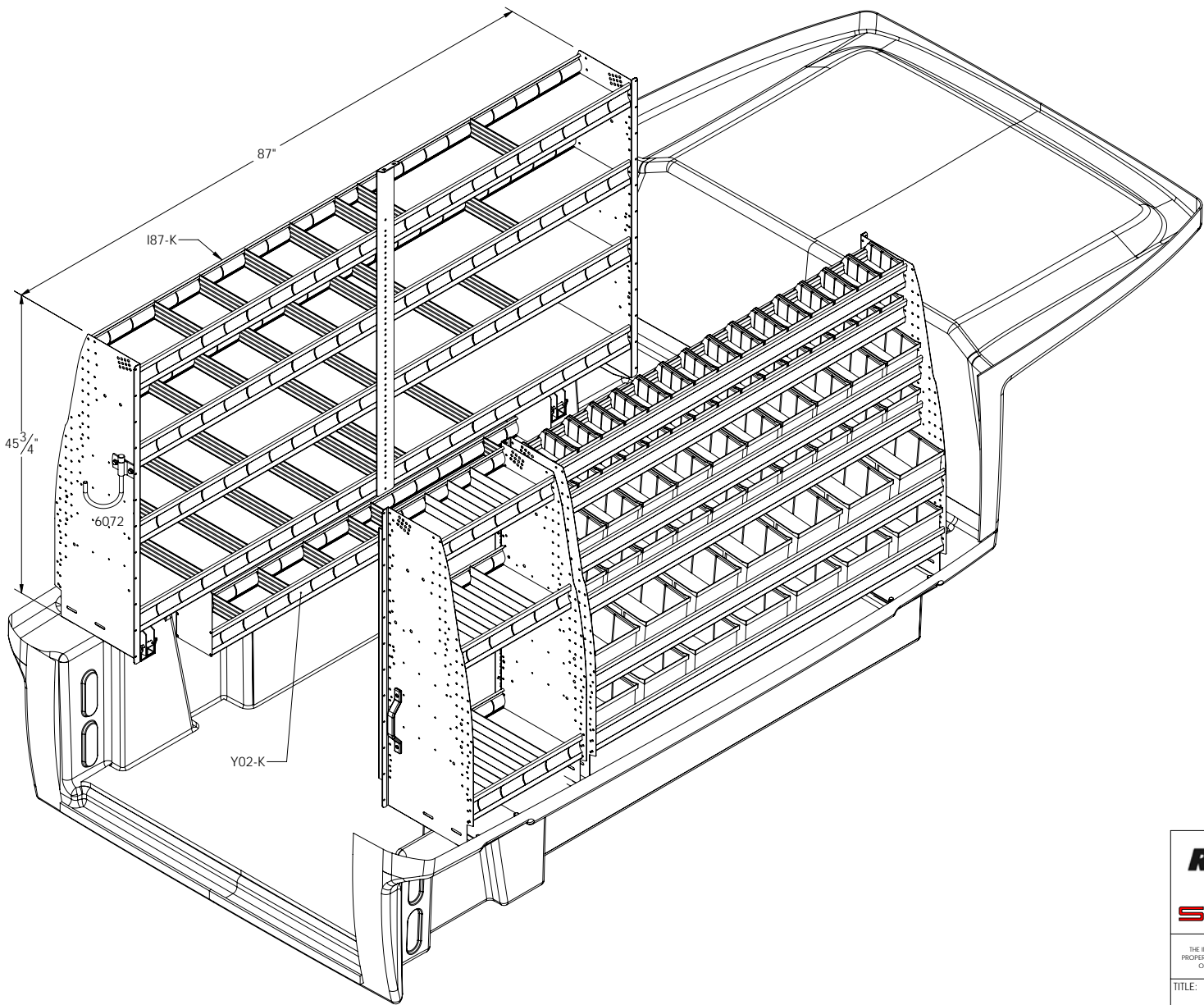

TABLE DE NOMENCLATURE / BOM TABLE		
No	DESCRIPTION	QTÉ/QTY
I87-K	CONTOURED SHELF UNIT, 4 DIVIDED SHELVES, 87"W X 45-3/4"H	1
Y02-K	HALF SHELF - 6"D X 60"W	1
6072	SWIVEL HOOK	1
M62-K	CONTOURED BIN UNIT, 6 SHELVES W/BINS, 62"W X 45-3/4"H	1
S20-K	LOCKER, THREE DIVIDED SHELVES, 20"W X 45-3/4"H	1
6093	PLASTIC GRAB HANDLE 9-1/2"	1



SPACEKAP PLUS 8'

**RANGER DESIGN**  
**SPACEKAP**

PROPRIETARY AND CONFIDENTIAL  
 THE INFORMATION CONTAINED IN THIS DRAWING IS THE SOLE PROPERTY OF RANGER DESIGN INC. ANY REPRODUCTION IN PART OR AS A WHOLE WITHOUT THE WRITTEN PERMISSION OF RANGER DESIGN INC IS PROHIBITED.

TITLE: ENSEMBLE POUR SERVICE SERVICE PACKAGE

SIZE <b>C</b>	DWG. NO. Z16-K8	REV 0
------------------	--------------------	----------

2010-03-04 SCALE: 1:10 SHEET 1 OF 2

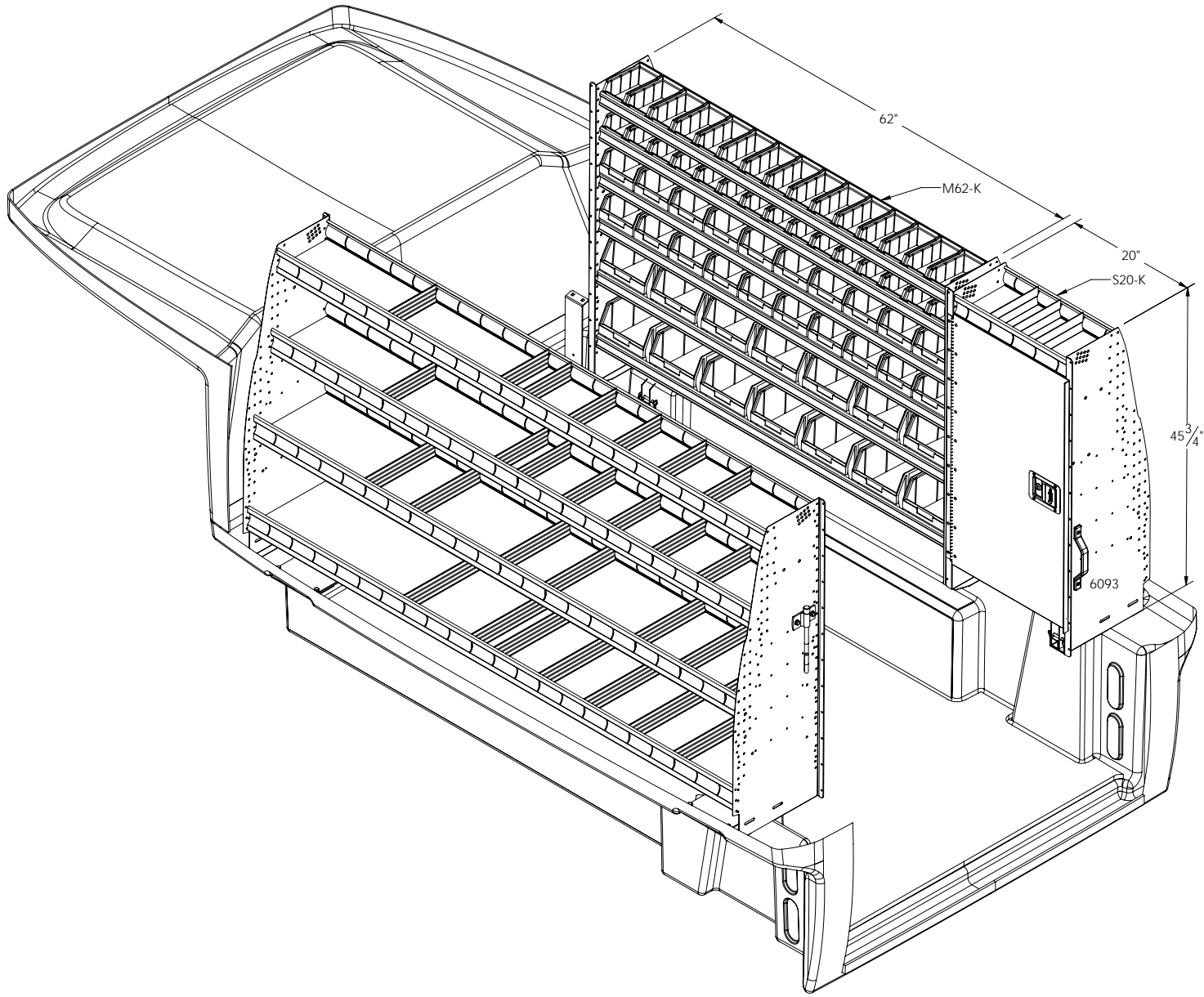

PROPRIETARY AND CONFIDENTIAL  
 THE INFORMATION CONTAINED IN THIS DRAWING IS THE SOLE  
 PROPERTY OF RANGER DESIGN INC. ANY REPRODUCTION IN PART  
 OR AS A WHOLE WITHOUT THE WRITTEN PERMISSION OF  
 RANGER DESIGN INC IS PROHIBITED.

TITLE:  
 ENSEMBLE POUR SERVICE  
 SERVICE PACKAGE

SIZE <b>C</b>	DWG. NO. Z16-K8	REV 0
------------------	--------------------	----------

# WORK STATION (Z17-K8)

Plus 8

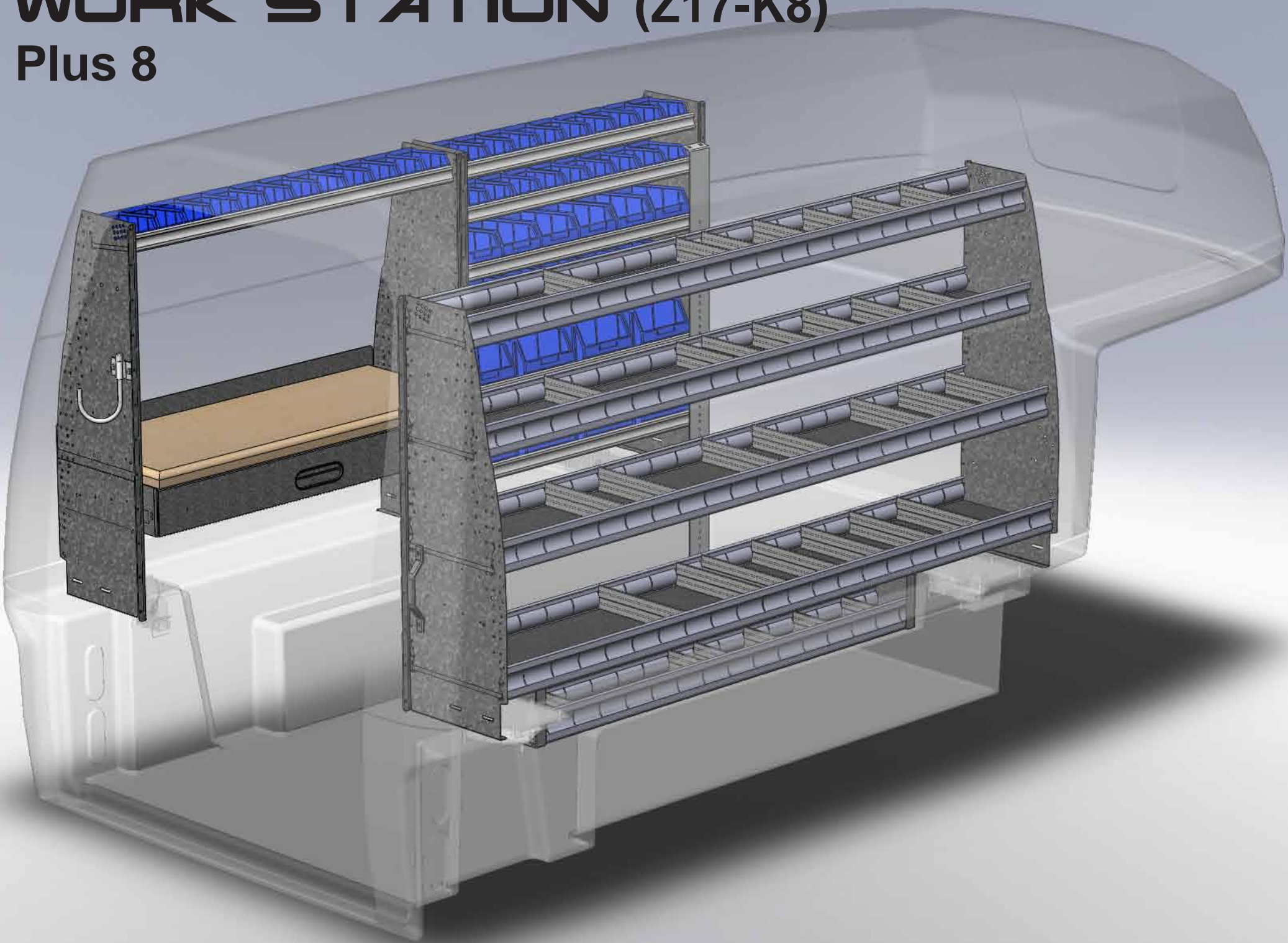
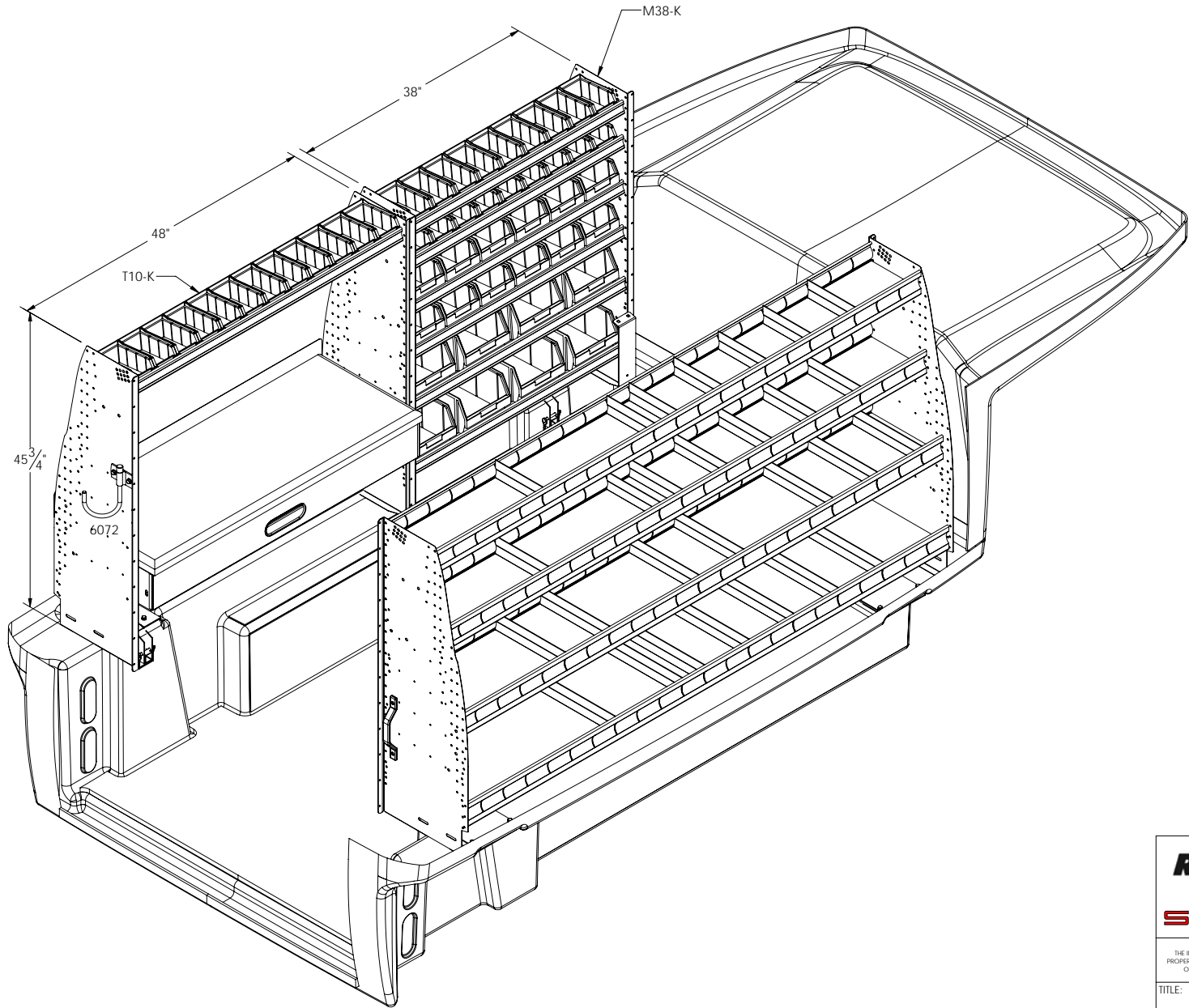

TABLE DE NOMENCLATURE / BOM TABLE		
No	DESCRIPTION	QTE/QTY
M38-K	CONTOURED BIN UNIT, 6 SHELVES W/BINS, 38"W X 45-1/2"H	1
T10-K	WORKBENCH WITH PULL OUT DRAWER, 18"D X 48"W	1
6072	SWIVEL HOOK	1
I87-K	CONTOURED SHELF UNIT, 4 DIVIDED SHELVES, 87"W X 45-3/4"H	1
Y02-K	HALF SHELF - 6"D X 60"W	1
6093	PLASTIC GRAB HANDLE 9-1/2"	1



SPACEKAP PLUS 8'

**RANGER DESIGN**  
**SPACEKAP**

PROPRIETARY AND CONFIDENTIAL  
 THE INFORMATION CONTAINED IN THIS DRAWING IS THE SOLE PROPERTY OF RANGER DESIGN INC. ANY REPRODUCTION IN PART OR AS A WHOLE WITHOUT THE WRITTEN PERMISSION OF RANGER DESIGN INC IS PROHIBITED.

TITLE: ENSEMBLE ATELIER WORKSTATION PACKAGE

SIZE <b>C</b>	DWG. NO. Z17-K8	REV 0
------------------	--------------------	----------

2010-03-04 SCALE: 1:10 SHEET 1 OF 2

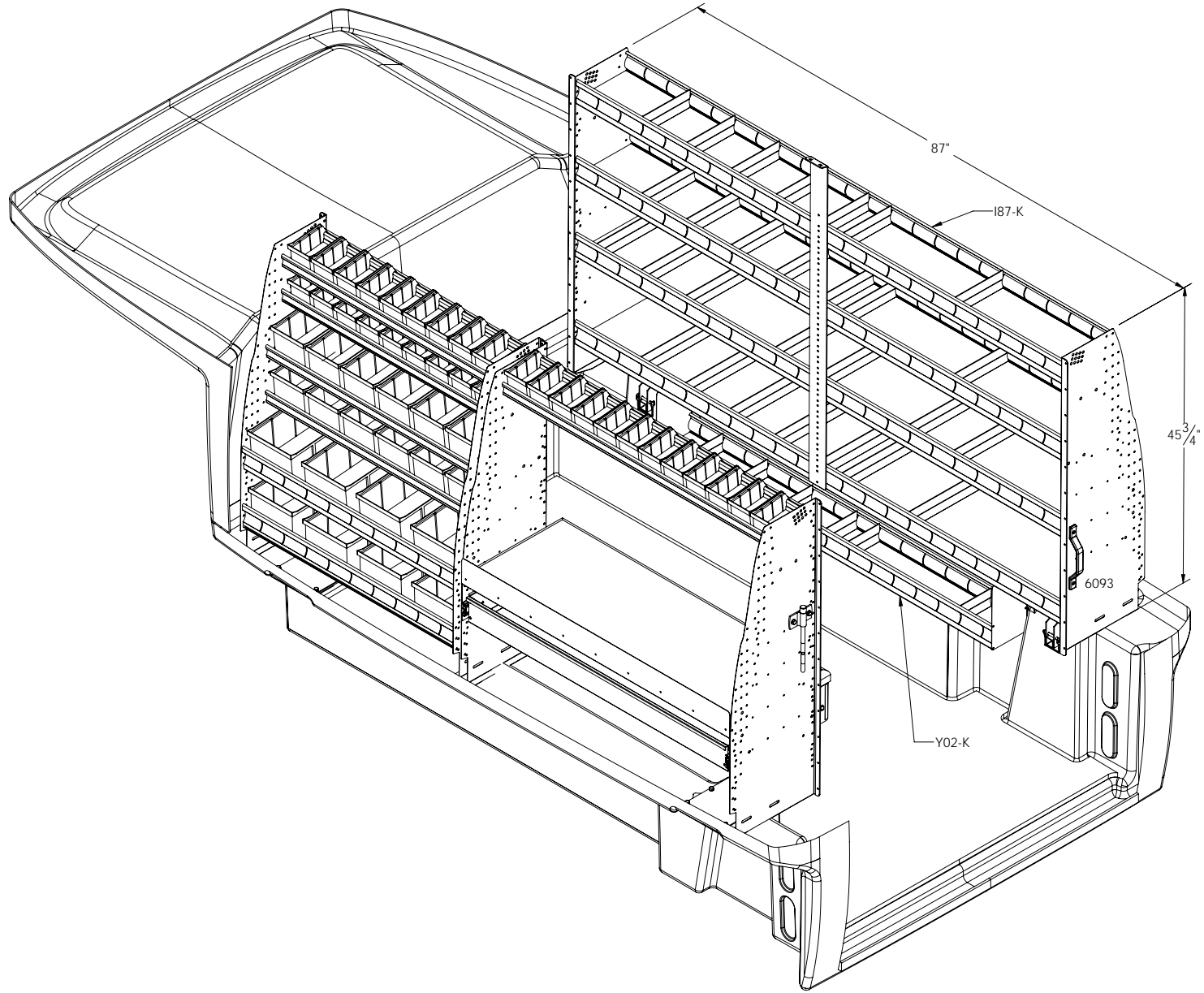

PROPRIETARY AND CONFIDENTIAL  
THE INFORMATION CONTAINED IN THIS DRAWING IS THE SOLE  
PROPERTY OF RANGER DESIGN INC. ANY REPRODUCTION IN PART  
OR AS A WHOLE WITHOUT THE WRITTEN PERMISSION OF  
RANGER DESIGN INC IS PROHIBITED.

TITLE: ENSEMBLE ATELIER  
WORKSTATION PACKAGE

SIZE <b>C</b>	DWG. NO. Z17-K8	REV 0
2010-03-04	SCALE: 1:10	SHEET 2 OF 2